

AÇOS DE ALTO LIMITE ELÁSTICO - HSS

EN 10219-3

À composição química dos aços de alto limite elástico são adicionadas pequenas quantidades de elementos de liga, como nióbio, vanádio ou titânico, que potenciam as suas propriedades físicas e mecânicas, garantindo, particularmente, uma maior resistência mecânica e maior resistência à corrosão. Esta estrutura química permite ainda reduzir o teor de carbono e com isso, melhorar alguns critérios como a soldabilidade e a ductilidade.

Estes aços estão particularmente indicados para situações em que o rácio resistência vs peso seja determinante, nomeadamente no desenvolvimento e construção de estruturas de carga, gruas, plataformas aéreas, funções telescópicas ou reboques de veículos pesados (aumento da carga útil).

Esta solução permite ainda uma redução significativa da espessura dos materiais, sem perda das suas características essenciais.

GAMA DIMENSIONAL

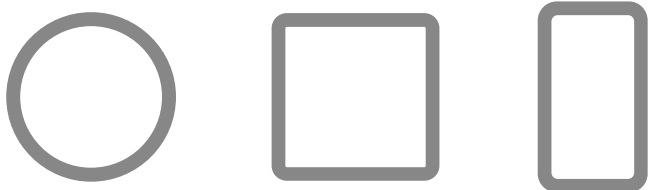

CARACTERÍSTICAS DIMENSIONAIS

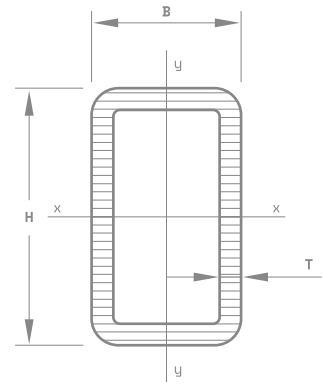
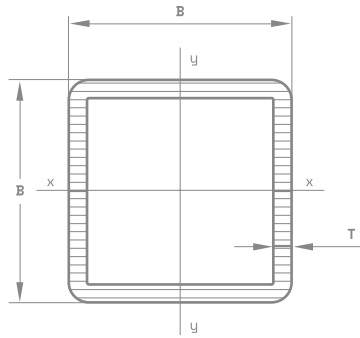
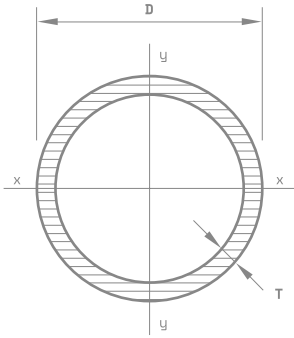

Dimensões exteriores

(D/B/H)

		Lados	
$D \leq 50\text{mm}$	$\pm 0,5\text{mm}$	$H, B < 100\text{mm}$	$\pm 1\% \text{ c/ mín. } \pm 0,5\text{mm}$
$D > 50\text{mm}$	$\pm 1\% \text{ de D}$	$100\text{mm} \leq H, B < 200\text{mm}$	$\pm 0,8\%$
		$H, B \geq 200\text{mm}$	$\pm 0,6\%$

Espessura da parede

(T)

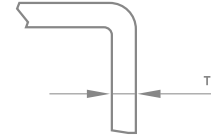
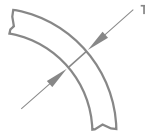

$D \leq 406,4\text{mm}$
 $T \leq 5,0\text{mm}: \pm 10\%$
 $T > 5,0\text{mm}: \pm 0,5\text{mm}$
 $D > 10\%$ e um máx. de $\pm 2\text{mm}$

$T \leq 5,0\text{mm}: \pm 10\%$
 $T > 5,0\text{mm}: \pm 0,5\text{mm}$

Esquadria dos lados

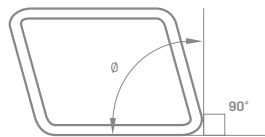

$90^\circ \pm 1^\circ$

Torção

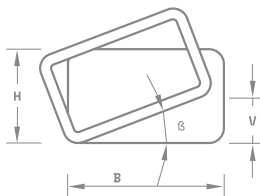

$2\text{mm} + 0,5\text{mm/m}$

Ovalização

2% para perfis com rácio diâmetro/espessura não superior a 100.

Concavidade / Convexidade

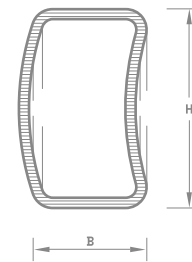

0,8% máximo com um mínimo de 0,5mm.

Forma dos cantos

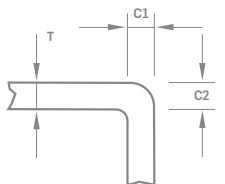

Espessura	C1, C2 e R
$T \leq 6\text{mm}$	$1,6 T - 2,4 T$
$6 < T \leq 10\text{mm}$	$2,0 T - 3,0 T$
$T > 10\text{mm}$	$2,4 T - 3,6 T$

Massa linear

(M)

$\pm 6\%$ sobre comp. individuais.

Rectitude

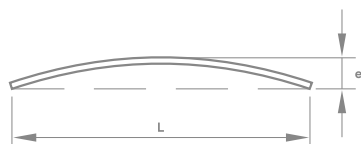

<input type="radio"/>	$0,20\%$ do comp. total + 3mm/m
<input type="checkbox"/>	$0,15\%$ do comp. total + 3mm/m

Comprimento exato

(L)

Comprimento L (mm)	Tolerância (mm)
< 6000	$+ 10\text{mm}$
$> 6000 < 10000$	$+ 15\text{mm}$
> 10000	$+ 5\text{mm} + 1\text{mm/m}$

TABELA DIMENSIONAL

Perfis Ocos Circulares

EN 10219 - 3

\emptyset	Espessura (mm)	Peso (Kg/m)	Tubos por Atado	Peso por Atado (Kg)	Secção (cm ²)	I - Momento de Inércia (cm ⁴)	W - Momento de Flexão Elástico (cm ³)	i - Raio de Giração (cm)
16	1,50	0,536	469	1508	0,683	0,182	0,227	0,515
16	2,00	0,691	469	1944	0,880	0,220	0,275	0,500
17,2	1,50	0,581	397	1384	0,740	0,230	0,267	0,558
17,2	1,80	0,684	100	410	0,871	0,262	0,304	0,548
17,2	2,00	0,750	397	1787	0,955	0,281	0,326	0,542
19	1,50	0,647	331	1285	0,825	0,318	0,335	0,621
19	2,00	0,838	331	1664	1,068	0,391	0,412	0,605
20	1,50	0,684	331	1358	0,872	0,375	0,375	0,656
20	2,00	0,888	331	1764	1,131	0,464	0,464	0,640
21,3	1,50	0,732	331	1454	0,933	0,460	0,432	0,702
21,3	2,0	0,952	331	1891	1,213	0,571	0,536	0,686
21,3	2,5	1,159	331	2302	1,477	0,664	0,623	0,671
22	1,5	0,758	331	1505	0,966	0,510	0,464	0,727
22	2,0	0,986	331	1958	1,257	0,635	0,577	0,711
23,5	1,5	0,814	271	1324	1,037	0,630	0,536	0,780
23,5	2,0	1,060	271	1724	1,351	0,787	0,670	0,763
25	1,5	0,869	271	1413	1,107	0,768	0,614	0,833
25	2,0	1,134	271	1844	1,445	0,963	0,770	0,816
25	2,3	1,288	271	2094	1,640	1,067	0,854	0,807
25	2,6	1,436	271	2335	1,830	1,163	0,930	0,797
25	2,9	1,581	271	2571	2,013	1,250	1,000	0,788
26,9	1,5	0,940	271	1528	1,197	0,969	0,720	0,900
26,9	2,0	1,228	271	1997	1,565	1,220	0,907	0,883
26,9	2,3	1,395	271	2268	1,778	1,356	1,008	0,874
26,9	2,5	1,504	271	2446	1,916	1,441	1,071	0,867
26,9	2,6	1,558	271	2533	1,985	1,482	1,102	0,864
26,9	2,9	1,716	271	2790	2,187	1,597	1,188	0,855
26,9	3,0	1,768	271	2875	2,253	1,634	1,215	0,852
30	1,5	1,054	217	1372	1,343	1,367	0,912	1,009
30	2,0	1,381	217	1798	1,759	1,733	1,155	0,992
30	2,3	1,571	217	2045	2,002	1,933	1,289	0,983
30	2,6	1,757	217	2288	2,238	2,119	1,413	0,973
30	2,9	1,938	217	2523	2,469	2,293	1,528	0,964
30,0	3,0	1,998	217	2601	2,545	2,347	1,565	0,960
31,8	1,5	1,121	217	1460	1,428	1,643	1,033	1,073
31,8	2,0	1,470	217	1914	1,872	2,088	1,313	1,056

Perfis Ocos Circulares

EN 10219 - 3

Ø	Espessura (mm)	Peso (Kg/m)	Tubos por Atado	Peso por Atado (Kg)	Secção (cm ²)	I - Momento de Inércia (cm ⁴)	W - Momento de Flexão Elástico (cm ³)	i - Raio de Giração (cm)
31,8	2,3	1,673	217	2178	2,132	2,333	1,467	1,046
31,8	2,6	1,872	217	2437	2,385	2,562	1,611	1,036
31,8	2,9	2,067	217	2691	2,633	2,777	1,746	1,027
32	1,5	1,128	217	1469	1,437	1,675	1,047	1,080
32	2,0	1,480	217	1927	1,885	2,130	1,331	1,063
32	2,3	1,685	217	2194	2,146	2,380	1,488	1,053
32	2,6	1,885	217	2454	2,401	2,615	1,634	1,044
32	2,9	2,081	217	2709	2,651	2,834	1,771	1,034
33,7	1,5	1,191	127	908	1,517	1,971	1,170	1,140
33,7	2,0	1,564	127	1192	1,992	2,512	1,491	1,123
33,7	2,3	1,781	127	1357	2,269	2,811	1,668	1,113
33,7	2,5	1,924	127	1466	2,450	3,001	1,781	1,107
33,7	2,6	1,994	127	1519	2,540	3,093	1,835	1,103
33,7	3,0	2,271	127	1731	2,893	3,441	2,042	1,091
33,7	3,2	2,407	127	1834	3,066	3,605	2,139	1,084
33,7	3,6	2,672	127	2036	3,404	3,910	2,321	1,072
33,7	4	2,930	127	2233	3,732	4,190	2,487	1,060
35	1,5	1,239	169	1256	1,579	2,219	1,268	1,186
35	2,0	1,628	169	1651	2,073	2,833	1,619	1,169
35	2,3	1,855	169	1881	2,363	3,174	1,814	1,159
35	2,6	2,077	169	2106	2,646	3,495	1,997	1,149
35	2,9	2,296	169	2328	2,925	3,798	2,170	1,140
35	3,2	2,510	169	2545	3,197	4,082	2,333	1,130
35	3,6	2,788	169	2827	3,551	4,434	2,534	1,117
35	4	3,058	169	3101	3,896	4,757	2,719	1,105
38	1,5	1,350	127	1029	1,720	2,869	1,510	1,292
38	2,0	1,776	127	1353	2,262	3,676	1,935	1,275
38	2,3	2,025	127	1543	2,580	4,127	2,172	1,265
38	2,6	2,270	127	1730	2,892	4,554	2,397	1,255
38	2,9	2,510	127	1913	3,198	4,958	2,610	1,245
38	3,2	2,746	127	2092	3,498	5,341	2,811	1,236
38	3,6	3,054	127	2327	3,891	5,818	3,062	1,223
38	4	3,354	127	2556	4,273	6,259	3,294	1,210
40	1,5	1,424	127	1085	1,814	3,367	1,683	1,362
40	2,0	1,874	127	1428	2,388	4,322	2,161	1,345
40	2,3	2,138	127	1629	2,724	4,858	2,429	1,335
40	2,6	2,398	127	1827	3,055	5,367	2,684	1,325
40	2,9	2,653	127	2022	3,380	5,851	2,925	1,316
40,0	3,0	2,737	127	2086	3,487	6,007	3,003	1,312

Perfis Ocos Circulares

EN 10219 - 3

Ø	Espessura (mm)	Peso (Kg/m)	Tubos por Atado	Peso por Atado (Kg)	Secção (cm ²)	I - Momento de Inércia (cm ⁴)	W - Momento de Flexão Elástico (cm ³)	i - Raio de Giração (cm)
40	3,2	2,904	127	2213	3,700	6,310	3,155	1,306
40	3,6	3,232	127	2463	4,117	6,885	3,442	1,293
40	4,0	3,551	127	2706	4,524	7,419	3,710	1,281
42	1,5	1,498	91	818	1,909	3,918	1,866	1,433
42	2,0	1,973	91	1077	2,513	5,039	2,400	1,416
42	2,3	2,252	91	1230	2,869	5,670	2,700	1,406
42	2,5	2,435	91	1330	3,102	6,075	2,893	1,399
42	2,6	2,526	91	1379	3,218	6,272	2,987	1,396
42	3,0	2,885	91	1575	3,676	7,030	3,347	1,383
42	3,2	3,062	91	1672	3,901	7,390	3,519	1,376
42	3,6	3,409	91	1861	4,343	8,075	3,845	1,364
42	4,0	3,749	91	2047	4,775	8,715	4,150	1,351
42,4	1,5	1,513	91	826	1,927	4,036	1,904	1,447
42,4	2,0	1,993	91	1088	2,538	5,192	2,449	1,430
42,4	2,3	2,275	91	1242	2,897	5,843	2,756	1,420
42,4	2,5	2,460	91	1343	3,134	6,261	2,953	1,413
42,4	2,6	2,552	91	1393	3,251	6,464	3,049	1,410
42,4	3,0	2,915	91	1592	3,713	7,247	3,419	1,397
42,4	3,2	3,094	91	1689	3,941	7,620	3,594	1,391
42,4	3,6	3,445	91	1881	4,388	8,329	3,929	1,378
42,4	4,0	3,788	91	2068	4,825	8,991	4,241	1,365
44,5	1,5	1,591	91	869	2,026	4,689	2,107	1,521
44,5	2,0	2,096	91	1144	2,670	6,043	2,716	1,504
44,5	2,3	2,394	91	1307	3,049	6,808	3,060	1,494
44,5	2,6	2,687	91	1467	3,422	7,540	3,389	1,484
44,5	2,9	2,975	91	1624	3,790	8,238	3,703	1,474
44,5	3,2	3,259	91	1779	4,152	8,906	4,002	1,465
44,5	3,6	3,631	91	1983	4,626	9,747	4,381	1,452
44,5	4,0	3,995	91	2181	5,089	10,537	4,736	1,439
45	1,5	1,609	91	879	2,050	4,854	2,158	1,539
45	2,0	2,121	91	1158	2,702	6,258	2,781	1,522
45	2,3	2,422	91	1322	3,085	7,052	3,134	1,512
45	2,6	2,719	91	1485	3,463	7,812	3,472	1,502
45	2,9	3,011	91	1644	3,836	8,538	3,795	1,492
45,0	3,0	3,107	91	1696	3,958	8,773	3,899	1,489
45,0	3,2	3,299	91	1801	4,202	9,232	4,103	1,482
45,0	3,6	3,676	91	2007	4,682	10,107	4,492	1,469
45,0	4,0	4,044	91	2208	5,152	10,929	4,857	1,456
48,3	1,5	1,731	91	945	2,205	6,044	2,503	1,655

Perfis Ocos Circulares

EN 10219 - 3

\emptyset	Espessura (mm)	Peso (Kg/m)	Tubos por Atado	Peso por Atado (Kg)	Secção (cm ²)	I - Momento de Inércia (cm ⁴)	W - Momento de Flexão Elástico (cm ³)	i - Raio de Giração (cm)
48,3	2,0	2,284	91	1247	2,909	7,810	3,234	1,638
48,3	2,3	2,609	91	1425	3,324	8,813	3,649	1,628
48,3	2,5	2,824	91	1542	3,597	9,460	3,917	1,622
48,3	2,6	2,930	91	1600	3,733	9,777	4,048	1,618
48,3	2,9	3,247	91	1773	4,136	10,700	4,431	1,608
48,3	3,0	3,351	91	1830	4,269	11,000	4,555	1,605
48,3	3,2	3,559	91	1943	4,534	11,586	4,797	1,599
48,3	3,6	3,969	91	2167	5,055	12,708	5,262	1,586
48,3	4,0	4,370	91	2386	5,567	13,768	5,701	1,573
48,3	4,5	4,861	91	2654	6,192	15,006	6,214	1,557
48,3	5,0	5,339	91	2915	6,802	16,153	6,689	1,541
50,0	1,5	1,794	91	980	2,286	6,727	2,691	1,716
50,0	2,0	2,368	91	1293	3,016	8,701	3,480	1,699
50,0	2,3	2,706	91	1477	3,447	9,825	3,930	1,688
50,0	2,6	3,039	91	1659	3,872	10,906	4,362	1,678
50,0	2,9	3,369	91	1839	4,291	11,944	4,778	1,668
50,0	3,0	3,477	91	1898	4,430	12,281	4,912	1,665
50,0	3,2	3,693	91	2016	4,705	12,941	5,176	1,658
50,0	3,6	4,119	91	2249	5,248	14,208	5,683	1,645
50,0	4,0	4,538	91	2478	5,781	15,405	6,162	1,632
50,8	1,5	1,824	91	996	2,323	7,065	2,781	1,744
50,8	2,0	2,407	91	1314	3,066	9,143	3,600	1,727
50,8	2,3	2,751	91	1502	3,504	10,327	4,066	1,717
50,8	2,6	3,091	91	1688	3,937	11,467	4,514	1,707
50,8	2,9	3,426	91	1871	4,364	12,562	4,946	1,697
50,8	3,2	3,756	91	2051	4,785	13,614	5,360	1,687
50,8	3,6	4,190	91	2288	5,338	14,952	5,887	1,674
50,8	4,0	4,617	91	2521	5,881	16,219	6,385	1,661
50,8	4,5	5,138	91	2805	6,546	17,705	6,971	1,645
50,8	5,0	5,647	91	3083	7,194	19,088	7,515	1,629
50,8	6,0	6,629	91	3619	8,445	21,566	8,490	1,598
55,0	1,5	1,979	61	724	2,521	9,027	3,283	1,892
55,0	2,0	2,614	61	957	3,330	11,709	4,258	1,875
55,0	2,3	2,989	61	1094	3,808	13,245	4,816	1,865
55,0	2,6	3,360	61	1230	4,280	14,726	5,355	1,855
55,0	2,9	3,726	61	1364	4,747	16,155	5,875	1,845
55,0	3,0	3,847	61	1408	4,901	16,620	6,044	1,842
55,0	3,2	4,088	61	1496	5,208	17,533	6,376	1,835
55,0	3,6	4,563	61	1670	5,813	19,292	7,015	1,822

Perfis Ocos Circulares

EN 10219 - 3

\emptyset	Espessura (mm)	Peso (Kg/m)	Tubos por Atado	Peso por Atado (Kg)	Secção (cm ²)	I - Momento de Inércia (cm ⁴)	W - Momento de Flexão Elástico (cm ³)	i - Raio de Giração (cm)
55,0	4,0	5,031	61	1841	6,409	20,965	7,624	1,809
57,0	1,5	2,053	61	751	2,615	10,077	3,536	1,963
57,0	2,0	2,713	61	993	3,456	13,084	4,591	1,946
57,0	2,3	3,103	61	1136	3,952	14,809	5,196	1,936
57,0	2,6	3,488	61	1277	4,443	16,475	5,781	1,926
57,0	2,9	3,869	61	1416	4,929	18,084	6,345	1,915
57,0	3,0	3,995	61	1462	5,089	18,608	6,529	1,912
57,0	3,2	4,246	61	1554	5,409	19,638	6,890	1,905
57,0	3,6	4,741	61	1735	6,039	21,625	7,588	1,892
57,0	4,0	5,228	61	1913	6,660	23,519	8,252	1,879
60,3	1,5	2,175	61	796	2,771	11,983	3,974	2,080
60,3	2,0	2,876	61	1053	3,663	15,581	5,168	2,062
60,3	2,3	3,290	61	1204	4,191	17,650	5,854	2,052
60,3	2,5	3,564	61	1304	4,540	18,993	6,300	2,045
60,3	2,6	3,700	61	1354	4,713	19,654	6,519	2,042
60,3	2,9	4,105	61	1502	5,229	21,592	7,162	2,032
60,3	3,0	4,239	61	1551	5,400	22,225	7,371	2,029
60,3	3,2	4,506	61	1649	5,740	23,468	7,784	2,022
60,3	3,6	5,034	61	1842	6,413	25,874	8,582	2,009
60,3	4,0	5,554	61	2033	7,075	28,173	9,344	1,996
60,3	4,5	6,193	61	2267	7,889	30,902	10,250	1,979
60,3	5,0	6,819	61	2496	8,687	33,477	11,103	1,963
60,3	6,0	8,035	61	2941	10,235	38,184	12,665	1,931
60,3	6,3	8,390	61	3071	10,688	39,487	13,097	1,922
60,3	8,0	10,318	61	3776	13,144	45,994	15,255	1,871
63,5	1,5	2,294	37	509	2,922	14,047	4,424	2,193
63,5	2,0	3,033	37	673	3,864	18,288	5,760	2,176
63,5	2,3	3,471	37	771	4,422	20,733	6,530	2,165
63,5	2,6	3,905	37	867	4,974	23,103	7,277	2,155
63,5	2,9	4,334	37	962	5,521	25,402	8,001	2,145
63,5	3,2	4,759	37	1056	6,062	27,630	8,702	2,135
63,5	3,6	5,318	37	1181	6,775	30,494	9,604	2,122
63,5	4,0	5,869	37	1303	7,477	33,238	10,469	2,108
63,5	4,5	6,548	37	1454	8,341	36,505	11,498	2,092
63,5	5,0	7,213	37	1601	9,189	39,597	12,471	2,076
63,5	6,0	8,508	37	1889	10,838	45,281	14,262	2,044
63,5	6,3	8,887	37	1973	11,321	46,862	14,760	2,035
63,5	8,0	10,950	37	2431	13,949	54,823	17,267	1,983
65,0	1,5	2,349	37	521	2,992	15,091	4,643	2,246

Perfis Ocos Circulares

EN 10219 - 3

\emptyset	Espessura (mm)	Peso (Kg/m)	Tubos por Atado	Peso por Atado (Kg)	Secção (cm ²)	I - Momento de Inércia (cm ⁴)	W - Momento de Flexão Elástico (cm ³)	i - Raio de Giração (cm)
65,0	2,0	3,107	37	690	3,958	19,658	6,049	2,229
65,0	2,3	3,556	37	789	4,530	22,293	6,859	2,218
65,0	2,6	4,001	37	888	5,097	24,851	7,646	2,208
65,0	2,9	4,441	37	986	5,658	27,332	8,410	2,198
65,0	3,2	4,877	37	1083	6,213	29,740	9,151	2,188
65,0	3,6	5,451	37	1210	6,944	32,837	10,104	2,175
65,0	4,0	6,017	37	1336	7,665	35,807	11,018	2,161
65,0	4,5	6,714	37	1491	8,553	39,349	12,107	2,145
65,0	5,0	7,398	37	1642	9,425	42,706	13,140	2,129
65,0	6,0	8,730	37	1938	11,121	48,892	15,044	2,097
65,0	6,3	9,120	37	2025	11,618	50,616	15,574	2,087
65,0	8,0	11,246	37	2497	14,326	59,326	18,254	2,035
70,0	1,5	2,534	37	563	3,228	18,942	5,412	2,422
70,0	2,0	3,354	37	745	4,273	24,717	7,062	2,405
70,0	2,3	3,840	37	852	4,892	28,058	8,017	2,395
70,0	2,6	4,322	37	959	5,505	31,308	8,945	2,385
70,0	2,9	4,799	37	1065	6,113	34,470	9,848	2,375
70,0	3,0	4,957	37	1100	6,315	35,504	10,144	2,371
70,0	3,2	5,272	37	1170	6,715	37,543	10,727	2,364
70,0	3,6	5,895	37	1309	7,510	41,509	11,860	2,351
70,0	4,0	6,511	37	1445	8,294	45,326	12,950	2,338
70,0	4,5	7,269	37	1614	9,260	49,893	14,255	2,321
70,0	5,0	8,015	37	1779	10,210	54,242	15,498	2,305
70,0	6,0	9,470	37	2102	12,064	62,309	17,803	2,273
70,0	6,3	9,897	37	2197	12,608	64,572	18,449	2,263
70,0	8,0	12,232	37	2716	15,582	76,120	21,748	2,210
76,1	1,5	2,760	37	613	3,515	24,465	6,430	2,638
76,1	2,0	3,655	37	811	4,656	31,979	8,404	2,621
76,1	2,3	4,186	37	929	5,333	36,339	9,550	2,610
76,1	2,5	4,538	37	1007	5,781	39,186	10,299	2,604
76,1	2,6	4,713	37	1046	6,004	40,592	10,668	2,600
76,1	2,9	5,235	37	1162	6,669	44,738	11,758	2,590
76,1	3,0	5,408	37	1201	6,890	46,096	12,115	2,587
76,1	3,2	5,753	37	1277	7,329	48,779	12,820	2,580
76,1	3,6	6,437	37	1429	8,200	54,006	14,194	2,566
76,1	4,0	7,112	37	1579	9,060	59,055	15,520	2,553
76,1	4,5	7,946	37	1764	10,122	65,121	17,115	2,536
76,1	5,0	8,767	37	1946	11,168	70,922	18,639	2,520
76,1	6,0	10,373	37	2303	13,214	81,759	21,487	2,487

Perfis Ocos Circulares

EN 10219 - 3

\emptyset	Espessura (mm)	Peso (Kg/m)	Tubos por Atado	Peso por Atado (Kg)	Secção (cm ²)	I - Momento de Inércia (cm ⁴)	W - Momento de Flexão Elástico (cm ³)	i - Raio de Giração (cm)
76,1	6,3	10,845	37	2408	13,815	84,818	22,291	2,478
76,1	8	13,436	37	2983	17,115	100,587	26,436	2,424
80	1,5	2,904	37	645	3,699	28,505	7,126	2,776
80	2	3,847	37	854	4,901	37,296	9,324	2,759
80	2,3	4,407	37	978	5,614	42,406	10,602	2,748
80	2,6	4,963	37	1102	6,322	47,396	11,849	2,738
80	2,9	5,514	37	1224	7,024	52,268	13,067	2,728
80,0	3,0	5,697	37	1265	7,257	53,866	13,466	2,724
80,0	3,2	6,061	37	1346	7,721	57,023	14,256	2,718
80,0	3,6	6,783	37	1506	8,641	63,184	15,796	2,704
80,0	4,0	7,497	37	1664	9,550	69,145	17,286	2,691
82,5	1,5	2,996	37	665	3,817	31,315	7,592	2,864
82,5	2,0	3,971	37	882	5,058	40,996	9,939	2,847
82,5	2,3	4,549	37	1010	5,795	46,630	11,304	2,837
82,5	2,6	5,123	37	1137	6,526	52,135	12,639	2,826
82,5	2,9	5,693	37	1264	7,252	57,514	13,943	2,816
82,5	3,2	6,258	37	1389	7,972	62,768	15,216	2,806
82,5	3,6	7,005	37	1555	8,923	69,582	16,868	2,792
82,5	4,0	7,744	37	1719	9,865	76,182	18,468	2,779
83,0	1,5	3,015	37	669	3,841	31,899	7,686	2,882
83,0	2,0	3,995	37	887	5,089	41,765	10,064	2,865
83,0	2,3	4,577	37	1016	5,831	47,507	11,448	2,854
83,0	2,6	5,155	37	1144	6,567	53,120	12,800	2,844
83,0	2,9	5,729	37	1272	7,298	58,604	14,121	2,834
83,0	3,0	5,919	37	1314	7,540	60,403	14,555	2,830
83,0	3,2	6,298	37	1398	8,022	63,961	15,412	2,824
83,0	3,6	7,049	37	1565	8,980	70,911	17,087	2,810
83,0	4,0	7,793	37	1730	9,927	77,645	18,710	2,797
83,0	4,0	7,793	37	1730	9,927	77,645	18,710	2,797
88,9	1,5	3,233	37	718	4,119	39,338	8,850	3,091
88,9	2,0	4,286	37	951	5,460	51,568	11,601	3,073
88,9	2,3	4,912	37	1090	6,257	58,701	13,206	3,063
88,9	2,5	5,327	37	1183	6,786	63,373	14,257	3,056
88,9	2,6	5,534	37	1229	7,049	65,684	14,777	3,053
88,9	2,9	6,151	37	1366	7,835	72,518	16,315	3,042
88,9	3,0	6,355	37	1411	8,096	74,764	16,820	3,039
88,9	3,2	6,763	37	1501	8,616	79,206	17,819	3,032
88,9	3,6	7,573	37	1681	9,647	87,899	19,775	3,018
88,9	4,0	8,375	37	1859	10,669	96,340	21,674	3,005

Perfis Ocos Circulares

EN 10219 - 3

\emptyset	Espessura (mm)	Peso (Kg/m)	Tubos por Atado	Peso por Atado (Kg)	Secção (cm ²)	I - Momento de Inércia (cm ⁴)	W - Momento de Flexão Elástico (cm ³)	i - Raio de Giração (cm)
88,9	4,5	9,366	37	2079	11,932	106,545	23,970	2,988
88,9	5,0	10,346	37	2297	13,179	116,374	26,181	2,972
88,9	6,0	12,267	37	2723	15,626	134,941	30,358	2,939
88,9	6,3	12,833	37	2849	16,348	140,236	31,549	2,929
88,9	8	15,961	37	3543	20,332	167,966	37,788	2,874
90,0	3,0	6,437	37	1429	8,200	77,670	17,260	3,078
90,0	4,0	8,484	37	1883	10,807	100,128	22,251	3,044
95,0	1,5	3,459	37	768	4,406	48,161	10,139	3,306
95,0	2,0	4,587	37	1018	5,843	63,203	13,306	3,289
95,0	2,3	5,258	37	1167	6,698	71,994	15,157	3,278
95,0	2,6	5,925	37	1315	7,547	80,611	16,971	3,268
95,0	2,9	6,587	37	1462	8,391	89,057	18,749	3,258
95,0	3,0	6,807	37	1511	8,671	91,835	19,334	3,254
95,0	3,2	7,245	37	1608	9,229	97,334	20,491	3,248
95,0	3,6	8,115	37	1802	10,337	108,112	22,760	3,234
95,0	4,0	8,977	37	1993	11,435	118,599	24,968	3,220
100,0	1,5	3,644	19	415	4,642	56,307	11,261	3,483
100,0	2,0	4,834	19	551	6,158	73,952	14,790	3,466
100,0	2,3	5,542	19	632	7,059	84,278	16,856	3,455
100,0	2,6	6,245	19	712	7,956	94,410	18,882	3,445
100,0	2,9	6,944	19	792	8,846	104,352	20,870	3,435
100,0	3,0	7,176	19	818	9,142	107,625	21,525	3,431
100,0	3,2	7,639	19	871	9,731	114,106	22,821	3,424
100,0	3,6	8,559	19	976	10,903	126,823	25,365	3,411
100,0	4,0	9,470	19	1080	12,064	139,215	27,843	3,397
100,0	4,5	10,598	19	1208	13,501	154,257	30,851	3,380
100,0	5,0	11,714	19	1335	14,923	168,812	33,762	3,363
100,0	6,0	13,909	19	1586	17,719	196,499	39,300	3,330
100,0	6,3	14,558	19	1660	18,545	204,446	40,889	3,320
100,0	7,0	16,055	19	1830	20,452	222,362	44,472	3,297
100,0	8,0	18,151	19	2069	23,122	246,482	49,296	3,265
101,6	1,5	3,703	19	422	4,717	59,095	11,633	3,539
101,6	2,0	4,913	19	560	6,258	77,632	15,282	3,522
101,6	2,3	5,632	19	642	7,175	88,485	17,418	3,512
101,6	2,5	6,110	19	697	7,783	95,609	18,821	3,505
101,6	2,6	6,348	19	724	8,086	99,138	19,515	3,501
101,6	2,9	7,059	19	805	8,992	109,593	21,573	3,491
101,6	3,0	7,295	19	832	9,293	113,035	22,251	3,488
101,6	3,2	7,765	19	885	9,892	119,854	23,593	3,481

Perfis Ocos Circulares

EN 10219 - 3

\emptyset	Espessura (mm)	Peso (Kg/m)	Tubos por Atado	Peso por Atado (Kg)	Secção (cm ²)	I - Momento de Inércia (cm ⁴)	W - Momento de Flexão Elástico (cm ³)	i - Raio de Giração (cm)
101,6	3,6	8,701	19	992	11,084	133,237	26,228	3,467
101,6	4,0	9,628	19	1098	12,265	146,284	28,796	3,454
101,6	4,5	10,776	19	1228	13,727	162,129	31,915	3,437
101,6	5,0	11,912	19	1358	15,174	177,469	34,935	3,420
101,6	6,0	14,146	19	1613	18,020	206,677	40,684	3,387
101,6	6,3	14,807	19	1688	18,862	215,067	42,336	3,377
101,6	8,0	18,467	19	2105	23,524	259,501	51,083	3,321
108,0	2,0	5,228	19	596	6,660	93,575	17,329	3,748
108,0	2,3	5,995	19	683	7,638	106,713	19,762	3,738
108,0	2,6	6,758	19	770	8,609	119,624	22,153	3,728
108,0	2,9	7,517	19	857	9,575	132,311	24,502	3,717
108,0	3,0	7,768	19	886	9,896	136,491	25,276	3,714
108,0	3,2	8,270	19	943	10,536	144,777	26,810	3,707
108,0	3,6	9,269	19	1057	11,807	161,057	29,825	3,693
108,0	4,0	10,259	19	1170	13,069	176,955	32,769	3,680
108,0	4,5	11,486	19	1309	14,632	196,297	36,351	3,663
108,0	5,0	12,701	19	1448	16,179	215,062	39,826	3,646
108,0	6,0	15,093	19	1721	19,227	250,906	46,464	3,612
108,0	6,3	15,801	19	1801	20,128	261,232	48,376	3,603
108,0	8,0	19,729	19	2249	25,133	316,170	58,550	3,547
114,3	2,0	5,539	19	631	7,056	111,267	19,469	3,971
114,3	2,3	6,353	19	724	8,093	126,948	22,213	3,961
114,3	2,5	6,893	19	786	8,781	137,259	24,017	3,954
114,3	2,6	7,162	19	816	9,124	142,373	24,912	3,950
114,3	2,9	7,967	19	908	10,149	157,546	27,567	3,940
114,3	3,0	8,234	19	939	10,490	162,548	28,442	3,936
114,3	3,2	8,768	19	1000	11,169	172,469	30,178	3,930
114,3	3,6	9,828	19	1120	12,520	191,984	33,593	3,916
114,3	4,0	10,881	19	1240	13,861	211,065	36,932	3,902
114,3	4,5	12,185	19	1389	15,523	234,319	41,001	3,885
114,3	5,0	13,478	19	1536	17,169	256,920	44,955	3,868
114,3	6,0	16,025	19	1827	20,414	300,212	52,530	3,835
114,3	6,3	16,780	19	1913	21,375	312,714	54,718	3,825
114,3	7,0	18,523	19	2112	23,597	341,037	59,674	3,802
114,3	8,0	20,972	19	2391	26,716	379,492	66,403	3,769
114,3	10,0	25,722	19	2932	32,767	449,663	78,681	3,704
120,0	2,0	5,820	19	663	7,414	129,081	21,513	4,173
120,0	2,3	6,676	19	761	8,505	147,327	24,555	4,162
120,0	2,6	7,528	19	858	9,589	165,291	27,549	4,152

Perfis Ocos Circulares

EN 10219 - 3

\emptyset	Espessura (mm)	Peso (Kg/m)	Tubos por Atado	Peso por Atado (Kg)	Secção (cm ²)	I - Momento de Inércia (cm ⁴)	W - Momento de Flexão Elástico (cm ³)	i - Raio de Giração (cm)
120,0	2,9	8,375	19	955	10,669	182,976	30,496	4,141
120,0	3,0	8,656	19	987	11,027	188,810	31,468	4,138
120,0	3,2	9,217	19	1051	11,742	200,385	33,397	4,131
120,0	3,6	10,334	19	1178	13,165	223,170	37,195	4,117
120,0	4,0	11,443	19	1305	14,577	245,477	40,913	4,104
120,0	4,5	12,818	19	1461	16,328	272,695	45,449	4,087
120,0	5,0	14,180	19	1617	18,064	299,188	49,865	4,070
120,0	6,0	16,868	19	1923	21,488	350,048	58,341	4,036
120,0	6,3	17,665	19	2014	22,504	364,765	60,794	4,026
120,0	8,0	22,097	19	2519	28,149	443,623	73,937	3,970
120,0	10,0	27,128	19	3093	34,558	527,002	87,834	3,905
125,0	2,9	8,732	23	1205	11,124	207,420	33,187	4,318
125,0	3,0	9,026	23	1246	11,498	214,054	34,249	4,315
125,0	3,2	9,612	23	1326	12,245	227,223	36,356	4,308
125,0	3,6	10,778	23	1487	13,730	253,163	40,506	4,294
125,0	4,0	11,936	23	1647	15,205	278,580	44,573	4,280
125,0	4,5	13,373	23	1845	17,035	309,627	49,540	4,263
125,0	5,0	14,797	23	2042	18,850	339,881	54,381	4,246
125,0	6,0	17,608	19	2007	22,431	398,066	63,691	4,213
125,0	6,3	18,442	19	2102	23,493	414,929	66,389	4,203
125,0	7,0	20,370	19	2322	25,950	453,241	72,519	4,179
125,0	8,0	23,083	19	2631	29,405	505,514	80,882	4,146
125,0	10,0	28,361	10	1702	36,128	601,762	96,282	4,081
127,0	2,0	6,165	14	518	7,854	153,437	24,163	4,420
127,0	2,3	7,073	14	594	9,010	175,200	27,591	4,410
127,0	2,6	7,977	14	670	10,161	196,646	30,968	4,399
127,0	2,9	8,875	14	746	11,306	217,776	34,295	4,389
127,0	3,0	9,174	14	771	11,687	224,750	35,394	4,385
127,0	3,2	9,770	14	821	12,446	238,595	37,574	4,378
127,0	3,6	10,956	14	920	13,956	265,875	41,870	4,365
127,0	4,0	12,133	14	1019	15,457	292,613	46,081	4,351
127,0	4,5	13,595	14	1142	17,318	325,287	51,226	4,334
127,0	5,0	15,044	14	1264	19,164	357,140	56,242	4,317
127,0	6,0	17,904	14	1504	22,808	418,441	65,896	4,283
127,0	6,3	18,753	14	1575	23,889	436,218	68,696	4,273
127,0	8,0	23,478	14	1972	29,908	531,801	83,748	4,217
127,0	10,0	28,854	14	2424	36,757	633,547	99,771	4,152
133,0	2,9	9,305	19	1061	11,853	250,903	37,730	4,601
133,0	3,0	9,618	19	1096	12,252	258,966	38,942	4,597

Perfis Ocos Circulares

EN 10219 - 3

Ø	Espessura (mm)	Peso (Kg/m)	Tubos por Atado	Peso por Atado (Kg)	Secção (cm ²)	I - Momento de Inércia (cm ⁴)	W - Momento de Flexão Elástico (cm ³)	i - Raio de Giração (cm)
133,0	3,2	10,243	19	1168	13,049	274,978	41,350	4,591
133,0	3,6	11,488	19	1310	14,635	306,550	46,098	4,577
133,0	4,0	12,725	19	1451	16,211	337,525	50,756	4,563
133,0	4,5	14,261	19	1626	18,166	375,417	56,454	4,546
133,0	5,0	15,783	19	1799	20,106	412,403	62,016	4,529
133,0	6,0	18,792	19	2142	23,939	483,716	72,739	4,495
133,0	6,3	19,685	19	2244	25,077	504,432	75,854	4,485
133,0	8,0	24,662	19	2811	31,416	616,106	92,647	4,428
133,0	10,0	30,334	19	3458	38,642	735,591	110,615	4,363
139,7	2,9	9,784	19	1115	12,463	291,683	41,758	4,838
139,7	3,0	10,114	19	1153	12,884	301,090	43,105	4,834
139,7	4,0	13,386	19	1526	17,053	392,859	56,243	4,800
139,7	4,5	15,004	19	1710	19,113	437,203	62,592	4,783
139,7	5,0	16,610	19	1894	21,159	480,541	68,796	4,766
139,7	6,0	19,783	19	2255	25,202	564,260	80,782	4,732
139,7	6,3	20,726	19	2363	26,403	588,621	84,269	4,722
139,7	7,0	22,908	19	2612	29,182	644,136	92,217	4,698
139,7	8,0	25,983	19	2962	33,100	720,289	103,119	4,665
139,7	10,0	31,986	19	3646	40,746	861,894	123,392	4,599
139,7	12,0	37,791	19	4308	48,142	989,993	141,731	4,535
139,7	12,5	39,212	19	4470	49,951	1 020,012	146,029	4,519
141,3	2,9	9,898	13	772	12,609	302,035	42,751	4,894
141,3	3,2	10,898	13	850	13,883	331,149	46,872	4,884
141,3	3,6	12,225	13	954	15,574	369,369	52,282	4,870
141,3	4,0	13,544	13	1056	17,254	406,911	57,595	4,856
141,3	4,5	15,182	13	1184	19,340	452,898	64,104	4,839
141,3	5,0	16,807	13	1311	21,410	497,853	70,468	4,822
141,3	6,0	20,020	13	1562	25,503	584,733	82,765	4,788
141,3	6,3	20,975	13	1636	26,719	610,023	86,344	4,778
141,3	8,0	26,299	13	2051	33,502	746,796	105,704	4,721
141,3	10,0	32,381	13	2526	41,249	894,059	126,548	4,656
141,3	12,0	38,265	13	2985	48,745	1 027,452	145,428	4,591
141,3	12,5	39,705	13	3097	50,580	1 058,739	149,857	4,575
152,0	2,9	10,663	13	832	13,584	377,620	49,687	5,272
152,0	3,0	11,024	13	860	14,043	389,867	51,298	5,269
152,0	3,2	11,743	13	916	14,959	414,209	54,501	5,262
152,0	3,6	13,175	13	1028	16,784	462,295	60,828	5,248
152,0	4,0	14,600	13	1139	18,598	509,591	67,052	5,235
152,0	4,5	16,369	13	1277	20,852	567,613	74,686	5,217

Perfis Ocos Circulares

EN 10219 - 3

\emptyset	Espessura (mm)	Peso (Kg/m)	Tubos por Atado	Peso por Atado (Kg)	Secção (cm ²)	I - Momento de Inércia (cm ⁴)	W - Momento de Flexão Elástico (cm ³)	i - Raio de Giração (cm)
152,0	5,0	18,126	13	1414	23,091	624,430	82,162	5,200
152,0	6,0	21,603	13	1685	27,520	734,518	96,647	5,166
152,0	6,3	22,637	13	1766	28,837	766,638	100,873	5,156
152,0	8,0	28,410	13	2216	36,191	940,970	123,812	5,099
152,0	10,0	35,019	13	2731	44,611	1 129,987	148,682	5,033
152,0	12,0	41,431	13	3232	52,779	1 302,580	171,392	4,968
152,0	12,5	43,003	13	3354	54,782	1 343,277	176,747	4,952
152,4	2,9	10,692	13	834	13,620	380,667	49,956	5,287
152,4	3,0	11,053	13	862	14,081	393,014	51,577	5,283
152,4	3,2	11,774	13	918	14,999	417,557	54,798	5,276
152,4	3,6	13,211	13	1030	16,829	466,042	61,160	5,262
152,4	4,0	14,639	13	1142	18,648	513,732	67,419	5,249
152,4	4,5	16,413	13	1280	20,909	572,241	75,097	5,231
152,4	5,0	18,176	13	1418	23,154	629,538	82,617	5,214
152,4	6,0	21,663	13	1690	27,596	740,565	97,187	5,180
152,4	6,3	22,699	13	1771	28,916	772,962	101,439	5,170
152,4	8,0	28,489	13	2222	36,292	948,817	124,517	5,113
152,4	10,0	35,118	13	2739	44,736	1 139,531	149,545	5,047
152,4	12,0	41,550	13	3241	52,930	1 313,722	172,404	4,982
152,4	12,5	43,127	13	3364	54,939	1 354,804	177,796	4,966
159,0	2,9	11,164	13	871	14,222	433,328	54,507	5,520
159,0	3,0	11,542	13	900	14,703	447,420	56,279	5,516
159,0	4,0	15,290	13	1193	19,478	585,334	73,627	5,482
159,0	4,5	17,146	13	1337	21,842	652,268	82,046	5,465
159,0	5,0	18,989	13	1481	24,190	717,876	90,299	5,448
159,0	6,0	22,639	10	1358	28,840	845,187	106,313	5,414
159,0	6,3	23,725	10	1424	30,222	882,381	110,991	5,403
159,0	7,0	26,240	10	1574	33,427	967,406	121,686	5,380
159,0	8,0	29,791	10	1787	37,950	1 084,671	136,437	5,346
159,0	10,0	36,746	10	2205	46,810	1 304,880	164,136	5,280
159,0	12,0	43,503	10	2610	55,418	1 506,876	189,544	5,215
159,0	12,5	45,161	10	2710	57,530	1 554,652	195,554	5,198
165,1	2,9	11,600	10	696	14,777	486,126	58,889	5,736
165,1	3,2	12,777	10	767	16,276	533,482	64,625	5,725
165,1	3,6	14,338	10	860	18,265	595,793	72,174	5,711
165,1	4,0	15,892	10	954	20,244	657,165	79,608	5,698
165,1	4,5	17,823	10	1069	22,704	732,571	88,743	5,680
165,1	5,0	19,742	10	1185	25,148	806,543	97,704	5,663
165,1	6,0	23,542	10	1413	29,990	950,252	115,112	5,629

Perfis Ocos Circulares

EN 10219 - 3

Ø	Espessura (mm)	Peso (Kg/m)	Tubos por Atado	Peso por Atado (Kg)	Secção (cm ²)	I - Momento de Inércia (cm ⁴)	W - Momento de Flexão Elástico (cm ³)	i - Raio de Giração (cm)
165,1	6,3	24,672	10	1480	31,430	992,282	120,204	5,619
165,1	8,0	30,995	10	1860	39,484	1 221,246	147,940	5,562
165,1	10,0	38,250	10	2295	48,726	1 471,285	178,230	5,495
165,1	12,0	45,308	10	2718	57,717	1 701,479	206,115	5,430
165,1	12,5	47,042	10	2823	59,926	1 756,054	212,726	5,413
168,3	2,9	11,829	10	710	15,069	515,463	61,255	5,849
168,3	3,0	12,230	10	734	15,579	532,283	63,254	5,845
168,3	4,0	16,208	10	972	20,647	697,092	82,839	5,811
168,3	4,5	18,178	10	1091	23,157	777,216	92,361	5,793
168,3	5,0	20,136	10	1208	25,651	855,846	101,705	5,776
168,3	6,0	24,015	10	1441	30,593	1 008,695	119,869	5,742
168,3	6,3	25,170	10	1510	32,063	1 053,421	125,184	5,732
168,3	7,0	27,845	10	1671	35,472	1 155,788	137,349	5,708
168,3	8,0	31,626	10	1898	40,288	1 297,271	154,162	5,675
168,3	10,0	39,039	10	2342	49,731	1 563,984	185,857	5,608
168,3	12,0	46,255	10	2775	58,924	1 809,966	215,088	5,542
168,3	12,5	48,028	10	2882	61,183	1 868,353	222,026	5,526
177,8	2,9	12,509	10	751	15,934	609,462	68,556	6,184
177,8	3,0	12,932	10	776	16,475	629,410	70,800	6,181
177,8	4,0	17,145	10	1029	21,840	825,086	92,811	6,146
177,8	4,5	19,232	10	1154	24,500	920,367	103,528	6,129
177,8	5,0	21,308	10	1278	27,143	1 013,969	114,057	6,112
177,8	6,0	25,421	10	1525	32,384	1 196,217	134,558	6,078
177,8	6,3	26,646	10	1599	33,943	1 249,621	140,565	6,068
177,8	7,0	29,485	7	1238	37,561	1 371,988	154,329	6,044
177,8	8,0	33,500	7	1407	42,675	1 541,437	173,390	6,010
177,8	10,0	41,382	7	1738	52,716	1 861,982	209,447	5,943
177,8	12,0	49,067	7	2061	62,505	2 159,055	242,863	5,877
177,8	12,5	50,957	7	2140	64,913	2 229,795	250,821	5,861
193,7	2,9	13,646	7	573	17,383	791,213	81,695	6,747
193,7	3,0	14,109	7	593	17,973	817,223	84,380	6,743
193,7	4,0	18,713	7	786	23,838	1 072,791	110,768	6,708
193,7	4,5	20,997	7	882	26,748	1 197,516	123,646	6,691
193,7	5,0	23,268	7	977	29,641	1 320,232	136,317	6,674
193,7	6,0	27,774	7	1167	35,381	1 559,723	161,045	6,640
193,7	6,3	29,116	7	1223	37,090	1 630,046	168,306	6,629
193,7	7,0	32,230	7	1354	41,057	1 791,435	184,970	6,605
193,7	8,0	36,637	7	1539	46,672	2 015,537	208,109	6,572
193,7	10,0	45,303	7	1903	57,711	2 441,588	252,100	6,504

Perfis Ocos Circulares

EN 10219 - 3

Ø	Espessura (mm)	Peso (Kg/m)	Tubos por Atado	Peso por Atado (Kg)	Secção (cm ²)	I - Momento de Inércia (cm ⁴)	W - Momento de Flexão Elástico (cm ³)	i - Raio de Giração (cm)
193,7	12,0	53,772	7	2258	68,499	2 839,200	293,154	6,438
193,7	12,5	55,858	7	2346	71,157	2 934,312	302,975	6,422
200,0	2,9	14,096	10	846	17,957	872,191	87,219	6,969
200,0	3,0	14,575	10	875	18,567	900,908	90,091	6,966
200,0	4,0	19,335	10	1160	24,630	1 183,229	118,323	6,931
200,0	4,5	21,696	7	911	27,638	1 321,121	132,112	6,914
200,0	5,0	24,045	7	1010	30,631	1 456,865	145,686	6,897
200,0	6,0	28,706	7	1206	36,568	1 721,994	172,199	6,862
200,0	7,0	33,318	7	1399	42,443	1 978,795	197,879	6,828
200,0	8,0	37,880	7	1591	48,255	2 227,444	222,744	6,794
200,0	10,0	46,857	7	1968	59,690	2 700,984	270,098	6,727
200,0	12,0	55,636	7	2337	70,874	3 143,985	314,399	6,660
200,0	12,5	57,800	7	2428	73,631	3 250,122	325,012	6,644
219,1	2,9	15,462	7	649	19,697	1 151,074	105,073	7,645
219,1	3,0	15,988	9	863	20,367	1 189,129	108,547	7,641
219,1	4,0	21,219	9	1146	27,030	1 563,836	142,751	7,606
219,1	4,5	23,816	9	1286	30,338	1 747,240	159,492	7,589
219,1	5,0	26,400	9	1426	33,631	1 928,043	175,997	7,572
219,1	6,0	31,532	9	1703	40,168	2 281,947	208,302	7,537
219,1	6,3	33,062	9	1785	42,117	2 386,139	217,813	7,527
219,1	7,0	36,615	9	1977	46,643	2 625,746	239,685	7,503
219,1	8,0	41,648	7	1749	53,055	2 959,633	270,163	7,469
219,1	10,0	51,567	7	2166	65,691	3 598,439	328,475	7,401
219,1	12,0	61,289	7	2574	78,075	4 199,882	383,376	7,334
219,1	12,5	63,688	7	2675	81,132	4 344,580	396,584	7,318
244,5	3,6	21,387	7	898	27,245	1 976,832	161,704	8,518
244,5	4,0	23,724	7	996	30,222	2 185,673	178,787	8,504
244,5	4,5	26,634	7	1119	33,929	2 443,761	199,899	8,487
244,5	5,0	29,532	7	1240	37,621	2 698,582	220,743	8,469
244,5	6,0	35,291	5	1059	44,956	3 198,535	261,639	8,435
244,5	6,3	37,009	5	1110	47,145	3 346,027	273,704	8,425
244,5	7,0	41,000	5	1230	52,229	3 685,750	301,493	8,401
244,5	8,0	46,660	5	1400	59,439	4 160,447	340,323	8,366
244,5	10,0	57,831	4	1388	73,670	5 073,147	414,981	8,298
244,5	12,0	68,806	4	1651	87,650	5 938,344	485,754	8,231
244,5	12,5	71,518	4	1716	91,106	6 147,418	502,856	8,214
273,0	4,0	26,536	8	1274	33,804	3 058,248	224,047	9,512
273,0	4,6	30,448	5	913	38,787	3 493,758	255,953	9,491
273,0	5,0	33,046	8	1586	42,097	3 780,815	276,983	9,477

Perfis Ocos Circulares

EN 10219 - 3

\emptyset	Espessura (mm)	Peso (Kg/m)	Tubos por Atado	Peso por Atado (Kg)	Secção (cm ²)	I - Momento de Inércia (cm ⁴)	W - Momento de Flexão Elástico (cm ³)	i - Raio de Giração (cm)
273,0	6,0	39,508	8	1896	50,328	4 487,084	328,724	9,442
273,0	6,3	41,437	5	1243	52,785	4 695,823	344,016	9,432
273,0	7,0	45,920	4	1102	58,496	5 177,302	379,290	9,408
273,0	8,0	52,282	4	1255	66,602	5 851,714	428,697	9,373
273,0	10,0	64,860	4	1557	82,624	7 154,093	524,109	9,305
273,0	12,0	77,240	4	1854	98,395	8 396,141	615,102	9,237
273,0	12,5	80,304	4	1927	102,298	8 697,449	637,176	9,221
285,0	4,0	27,720	4	665	35,312	3 485,996	244,631	9,936
285,0	4,5	31,129	4	747	39,655	3 901,061	273,759	9,918
285,0	5,0	34,526	4	829	43,982	4 311,640	302,571	9,901
285,0	6,0	41,283	4	991	52,590	5 119,465	359,261	9,866
285,0	6,3	43,301	4	1039	55,160	5 358,376	376,026	9,856
285,0	8,0	54,650	4	1312	69,618	6 682,689	468,961	9,798
285,0	10,0	67,819	4	1628	86,394	8 177,713	573,875	9,729
285,0	12,0	80,791	4	1939	102,919	9 606,548	674,144	9,661
285,0	12,5	84,003	4	2016	107,010	9 953,649	698,502	9,644
323,9	4,0	31,557	4	757	40,200	5 143,165	317,577	11,311
323,9	5,0	39,323	4	944	50,093	6 369,425	393,296	11,276
323,9	6,0	47,039	4	1129	59,923	7 572,467	467,581	11,241
323,9	6,3	49,345	4	1184	62,859	7 928,897	489,589	11,231
323,9	7,0	54,707	4	1313	69,690	8 752,588	540,450	11,207
323,9	8,0	62,325	4	1496	79,394	9 910,081	611,922	11,172
323,9	10,0	77,412	4	1858	98,615	12 158,342	750,747	11,104
323,9	12,0	92,303	4	2215	117,584	14 319,559	884,196	11,035
323,9	12,5	95,995	4	2304	122,286	14 846,530	916,735	11,019

Perfis Ocos Quadrados

EN 10219 - 3

Dimensões	Espessura (mm)	Peso (Kg/m)	Tubos por Atado	Peso por Atado (Kg)	Secção (cm ²)	I - Momento de Inércia (cm ⁴)	W - Momento de Flexão Elástico (cm ³)	i - Raio de Giração (cm)
15	1,5	0,590	360	1274	0,75	0,22	0,29	0,54
15	2,0	0,736	360	1590	0,94	0,25	0,33	0,51
16	1,5	0,637	360	1376	0,81	0,27	0,34	0,58
16	2,0	0,798	360	1724	1,02	0,31	0,39	0,56
18	1,5	0,732	289	1269	0,93	0,41	0,45	0,66
18	2,0	0,924	289	1602	1,18	0,48	0,53	0,64

Perfis Ocos Quadrados

EN 10219 - 3

Dimensões	Espessura (mm)	Peso (Kg/m)	Tubos por Atado	Peso por Atado (Kg)	Secção (cm ²)	I - Momento de Inércia (cm ⁴)	W - Momento de Flexão Elástico (cm ³)	i - Raio de Giração (cm)
19	1,5	0,779	225	1052	0,99	0,49	0,52	0,70
19	2,0	0,987	225	1332	1,26	0,58	0,61	0,68
20	1,5	0,826	225	1115	1,05	0,58	0,58	0,74
20	2,0	1,050	225	1418	1,34	0,69	0,69	0,72
22	1,5	0,920	196	1082	1,17	0,80	0,73	0,83
22	2,0	1,175	196	1382	1,50	0,96	0,87	0,80
25	1,5	1,061	196	1248	1,35	1,22	0,97	0,95
25	2,0	1,364	196	1604	1,74	1,48	1,19	0,92
25	2,5	1,640	196	1929	2,09	1,69	1,35	0,90
25	3,0	1,890	196	2223	2,41	1,84	1,47	0,87
30	1,5	1,297	169	1315	1,65	2,20	1,46	1,15
30	2,0	1,678	169	1701	2,14	2,72	1,81	1,13
30	2,5	2,032	169	2060	2,59	3,16	2,10	1,10
30	3,0	2,361	169	2394	3,01	3,50	2,34	1,08
35	1,5	1,532	121	1112	1,95	3,60	2,05	1,36
35	2,0	1,992	121	1446	2,54	4,51	2,58	1,33
35	3,0	2,832	121	2056	3,61	5,95	3,40	1,28
35	4,0	3,570	121	2592	4,55	6,93	3,96	1,23
40	1,5	1,768	121	1284	2,25	5,49	2,75	1,56
40	2,0	2,306	121	1674	2,94	6,94	3,47	1,54
40	2,5	2,817	121	2045	3,59	8,22	4,11	1,51
40	3,0	3,303	121	2398	4,21	9,32	4,66	1,49
40	4,0	4,198	64	1612	5,35	11,07	5,54	1,44
40	5,0	4,990	64	1916	6,36	12,26	6,13	1,39
45	1,5	2,003	100	1202	2,55	7,96	3,54	1,77
45	2,0	2,620	100	1572	3,34	10,12	4,50	1,74
45	3,0	3,774	100	2264	4,81	13,78	6,12	1,69
45	4,0	4,826	64	1853	6,15	16,61	7,38	1,64
50	1,5	2,239	81	1088	2,85	11,07	4,43	1,97
50	2,0	2,934	81	1426	3,74	14,15	5,66	1,95
50	2,5	3,602	81	1751	4,59	16,94	6,78	1,92
50	3,0	4,245	81	2063	5,41	19,47	7,79	1,90
50	4,0	5,454	64	2094	6,95	23,74	9,49	1,85
50	5,0	6,560	49	1929	8,36	27,04	10,82	1,80
50	6,0	7,562	49	2223	9,63	29,45	11,78	1,75
60	1,5	2,710	64	1041	3,45	19,52	6,51	2,38
60	2,0	3,562	64	1368	4,54	25,14	8,38	2,35
60	2,5	4,387	64	1685	5,59	30,34	10,11	2,33
60	3,0	5,187	64	1992	6,61	35,13	11,71	2,31

Perfis Ocos Quadrados

EN 10219 - 3

Dimensões	Espessura (mm)	Peso (Kg/m)	Tubos por Atado	Peso por Atado (Kg)	Secção (cm ²)	I - Momento de Inércia (cm ⁴)	W - Momento de Flexão Elástico (cm ³)	i - Raio de Giração (cm)
60	4,0	6,710	42	1691	8,55	43,55	14,52	2,26
60	5,0	8,130	36	1756	10,36	50,49	16,83	2,21
60	6,0	9,446	30	1700	12,03	56,07	18,69	2,16
60	6,3	9,553	30	1720	12,17	54,41	18,14	2,11
60	8,0	11,337	16	1088	14,44	58,57	19,52	2,01
70	1,5	3,181	49	935	4,05	31,46	8,99	2,79
70	2,0	4,190	49	1232	5,34	40,73	11,64	2,76
70	2,5	5,172	49	1521	6,59	49,41	14,12	2,74
70	3,0	6,129	49	1802	7,81	57,53	16,44	2,71
70	4,0	7,966	49	2342	10,15	72,12	20,61	2,67
70	5,0	9,700	25	1455	12,36	84,63	24,18	2,62
70	6,0	11,330	25	1700	14,43	95,17	27,19	2,57
70	6,3	11,531	25	1730	14,69	93,77	26,79	2,53
70	8,0	13,849	16	1330	17,64	104,11	29,74	2,43
76	3,0	6,695	36	1446	8,53	74,69	19,65	2,96
80	1,5	3,652	36	789	4,65	47,48	11,87	3,19
80	2,0	4,818	36	1041	6,14	61,70	15,42	3,17
80	3,0	7,071	36	1527	9,01	87,84	21,96	3,12
80	4,0	9,222	36	1992	11,75	111,04	27,76	3,07
80	5,0	11,270	25	1691	14,36	131,44	32,86	3,03
80	6,0	13,214	25	1982	16,83	149,18	37,29	2,98
80	6,3	13,510	25	2027	17,21	148,51	37,13	2,94
80	8,0	16,361	15	1472	20,84	168,38	42,09	2,84
90	3,0	8,013	30	1442	10,21	127,28	28,29	3,53
90	4,0	10,478	30	1886	13,35	161,92	35,98	3,48
90	5,0	12,840	25	1926	16,36	192,93	42,87	3,43
90	6,0	15,098	20	1812	19,23	220,48	48,99	3,39
90	6,3	15,488	20	1859	19,73	221,13	49,14	3,35
90	8,0	18,873	15	1699	24,04	254,59	56,58	3,25
92	4,0	10,729	36	2317	13,67	173,67	37,75	3,56
100	2,0	6,074	25	911	7,74	123,01	24,60	3,99
100	3,0	8,955	25	1343	11,41	177,05	35,41	3,94
100	3,5	10,358	25	1554	13,19	202,28	40,46	3,92
100	4,0	11,734	25	1760	14,95	226,35	45,27	3,89
100	4,5	13,085	20	1570	16,67	249,29	49,86	3,87
100	5,0	14,410	20	1729	18,36	271,10	54,22	3,84
100	6,0	16,982	20	2038	21,63	311,47	62,29	3,79
100	6,3	17,466	20	2096	22,25	314,17	62,83	3,76
100	7,0	19,121	16	1836	24,36	337,04	67,41	3,72

Perfis Ocos Quadrados

EN 10219 - 3

Dimensões	Espessura (mm)	Peso (Kg/m)	Tubos por Atado	Peso por Atado (Kg)	Secção (cm ²)	I - Momento de Inércia (cm ⁴)	W - Momento de Flexão Elástico (cm ³)	i - Raio de Giração (cm)
100	8,0	21,385	15	1925	27,24	365,94	73,19	3,67
100	10,0	25,565	15	2301	32,57	411,08	82,22	3,55
110	3,0	9,897	20	1188	12,61	238,34	43,33	4,35
110	3,5	11,457	20	1375	14,59	272,85	49,61	4,32
110	4,0	12,990	20	1559	16,55	305,94	55,62	4,30
110	4,5	14,498	20	1740	18,47	337,63	61,39	4,28
110	5,0	15,980	20	1918	20,36	367,95	66,90	4,25
110	6,0	18,866	20	2264	24,03	424,57	77,19	4,20
110	6,3	19,444	20	2333	24,77	430,14	78,21	4,17
110	7,0	21,319	16	2047	27,16	463,15	84,21	4,13
110	8,0	23,897	16	2294	30,44	505,64	91,93	4,08
110	10,0	28,705	16	2756	36,57	574,80	104,51	3,96
120	3,0	10,839	20	1301	13,81	312,35	52,06	4,76
120	3,5	12,556	20	1507	15,99	358,17	59,69	4,73
120	4,0	14,246	20	1710	18,15	402,28	67,05	4,71
120	4,5	15,911	20	1909	20,27	444,70	74,12	4,68
120	5,0	17,550	20	2106	22,36	485,47	80,91	4,66
120	6,0	20,750	20	2490	26,43	562,16	93,69	4,61
120	6,3	21,422	20	2571	27,29	571,55	95,26	4,58
120	7,0	23,517	12	1693	29,96	617,26	102,88	4,54
120	8,0	26,409	12	1901	33,64	676,88	112,81	4,49
120	10,0	31,845	12	2293	40,57	776,81	129,47	4,38
120	12,0	35,843	6	1290	45,66	805,70	134,28	4,20
120	12,5	36,929	6	1329	47,04	817,01	136,17	4,17
125	3,0	11,310	20	1357	14,41	354,50	56,72	4,96
125	3,5	13,105	20	1573	16,69	406,80	65,09	4,94
125	4,0	14,874	20	1785	18,95	457,23	73,16	4,91
125	4,5	16,617	20	1994	21,17	505,83	80,93	4,89
125	5,0	18,335	20	2200	23,36	552,62	88,42	4,86
125	6,0	21,692	20	2603	27,63	640,89	102,54	4,82
125	6,3	22,411	20	2689	28,55	652,59	104,41	4,78
125	7,0	24,616	16	2363	31,36	705,69	112,91	4,74
125	8,0	27,665	16	2656	35,24	775,32	124,05	4,69
125	10,0	33,415	12	2406	42,57	893,42	142,95	4,58
130	3,0	11,781	20	1414	15,01	400,28	61,58	5,16
130	3,5	13,655	20	1639	17,39	459,64	70,71	5,14
130	4,0	15,502	20	1860	19,75	516,97	79,53	5,12
130	4,5	17,324	20	2079	22,07	572,31	88,05	5,09
130	5,0	19,120	20	2294	24,36	625,68	96,26	5,07

Perfis Ocos Quadrados

EN 10219 - 3

Dimensões	Espessura (mm)	Peso (Kg/m)	Tubos por Atado	Peso por Atado (Kg)	Secção (cm ²)	I - Momento de Inércia (cm ⁴)	W - Momento de Flexão Elástico (cm ³)	i - Raio de Giração (cm)
130	6,0	22,634	20	2716	28,83	726,64	111,79	5,02
130	6,3	23,401	20	2808	29,81	740,94	113,99	4,99
130	7,0	25,715	16	2469	32,76	802,17	123,41	4,95
130	8,0	28,921	16	2776	36,84	882,85	135,82	4,90
130	10,0	34,985	12	2519	44,57	1021,10	157,09	4,79
130	12,0	39,611	12	2852	50,46	1075,24	165,42	4,62
130	12,5	40,854	12	2941	52,04	1093,42	168,22	4,58
140	3,0	12,723	20	1527	16,21	503,34	71,91	5,57
140	3,5	14,754	20	1770	18,79	578,66	82,67	5,55
140	4,0	16,758	16	1609	21,35	651,62	93,09	5,52
140	4,5	18,737	16	1799	23,87	722,24	103,18	5,50
140	5,0	20,690	16	1986	26,36	790,56	112,94	5,48
140	6,0	24,518	16	2354	31,23	920,43	131,49	5,43
140	6,3	25,379	16	2436	32,33	940,82	134,40	5,39
140	7,0	27,913	12	2010	35,56	1020,68	145,81	5,36
140	8,0	31,433	12	2263	40,04	1126,77	160,97	5,30
140	10,0	38,125	12	2745	48,57	1311,67	187,38	5,20
140	12,0	43,379	9	2342	55,26	1398,33	199,76	5,03
140	12,5	44,779	9	2418	57,04	1425,23	203,60	5,00
150	3,0	13,665	16	1312	17,41	622,73	83,03	5,98
150	3,5	15,853	16	1522	20,19	716,64	95,55	5,96
150	4,0	18,014	16	1729	22,95	807,82	107,71	5,93
150	4,5	20,150	16	1934	25,67	896,30	119,51	5,91
150	5,0	22,260	16	2137	28,36	982,12	130,95	5,89
150	6,0	26,402	16	2535	33,63	1145,91	152,79	5,84
150	6,3	27,357	16	2626	34,85	1173,71	156,49	5,80
150	7,0	30,111	12	2168	38,36	1275,59	170,08	5,77
150	8,0	33,945	12	2444	43,24	1411,83	188,24	5,71
150	10,0	41,265	9	2228	52,57	1652,53	220,34	5,61
150	12,0	47,147	9	2546	60,06	1779,77	237,30	5,44
150	12,5	48,704	9	2630	62,04	1817,44	242,33	5,41
160	3,0	14,607	12	1052	18,61	759,64	94,95	6,39
160	3,5	16,952	12	1221	21,59	874,97	109,37	6,37
160	4,0	19,270	12	1387	24,55	987,17	123,40	6,34
160	4,5	21,563	12	1553	27,47	1096,29	137,04	6,32
160	5,0	23,830	12	1716	30,36	1202,36	150,29	6,29
160	6,0	28,286	12	2037	36,03	1405,48	175,69	6,25
160	6,3	29,335	12	2112	37,37	1442,13	180,27	6,21
160	7,0	32,309	12	2326	41,16	1569,69	196,21	6,18

Perfis Ocos Quadrados

EN 10219 - 3

Dimensões	Espessura (mm)	Peso (Kg/m)	Tubos por Atado	Peso por Atado (Kg)	Secção (cm ²)	I - Momento de Inércia (cm ⁴)	W - Momento de Flexão Elástico (cm ³)	i - Raio de Giração (cm)
160	8,0	36,457	12	2625	46,44	1741,23	217,65	6,12
160	10,0	44,405	9	2398	56,57	2047,67	255,96	6,02
160	12,0	50,915	9	2749	64,86	2224,36	278,05	5,86
160	12,5	52,629	9	2842	67,04	2275,04	284,38	5,83
175	3,0	16,020	12	1153	20,41	1000,48	114,34	7,00
175	3,5	18,600	12	1339	23,69	1153,68	131,85	6,98
175	4,0	21,154	12	1523	26,95	1303,12	148,93	6,95
175	4,5	23,682	12	1705	30,17	1448,83	165,58	6,93
175	5,0	26,185	12	1885	33,36	1590,86	181,81	6,91
175	6,0	31,112	12	2240	39,63	1864,03	213,03	6,86
175	6,3	32,302	12	2326	41,15	1916,90	219,07	6,83
175	7,0	35,606	9	1923	45,36	2090,47	238,91	6,79
175	8,0	40,225	9	2172	51,24	2325,48	265,77	6,74
175	10,0	49,115	9	2652	62,57	2750,91	314,39	6,63
175	12,0	56,567	6	2036	72,06	3020,15	345,16	6,47
175	12,5	58,517	6	2107	74,54	3095,00	353,71	6,44
180	3,0	16,491	12	1187	21,01	1090,83	121,20	7,21
180	3,5	19,150	12	1379	24,39	1258,28	139,81	7,18
180	4,0	21,782	12	1568	27,75	1421,74	157,97	7,16
180	4,5	24,389	12	1756	31,07	1581,26	175,70	7,13
180	5,0	26,970	12	1942	34,36	1736,87	192,99	7,11
180	6,0	32,054	12	2308	40,83	2036,52	226,28	7,06
180	6,3	33,292	12	2397	42,41	2095,65	232,85	7,03
180	7,0	36,705	9	1982	46,76	2286,70	254,08	6,99
180	8,0	41,481	9	2240	52,84	2545,86	282,87	6,94
180	10,0	50,685	9	2737	64,57	3016,80	335,20	6,84
180	12,0	58,451	6	2104	74,46	3322,19	369,13	6,68
180	12,5	60,479	6	2177	77,04	3406,43	378,49	6,65
200	4,0	24,294	9	1312	30,95	1968,13	196,81	7,97
200	4,5	27,215	9	1470	34,67	2191,54	219,15	7,95
200	5,0	30,110	9	1626	38,36	2410,09	241,01	7,93
200	6,0	35,822	9	1934	45,63	2832,75	283,27	7,88
200	6,3	37,248	9	2011	47,45	2921,53	292,15	7,85
200	7,0	41,101	9	2219	52,36	3194,10	319,41	7,81
200	8,0	46,505	9	2511	59,24	3566,25	356,63	7,76
200	10,0	56,965	6	2051	72,57	4251,06	425,11	7,65
200	12,0	65,987	6	2376	84,06	4730,22	473,02	7,50
200	12,5	68,329	6	2460	87,04	4859,42	485,94	7,47
220	4,0	26,806	9	1448	34,15	2639,14	239,92	8,79

Perfis Ocos Quadrados

EN 10219 - 3

Dimensões	Espessura (mm)	Peso (Kg/m)	Tubos por Atado	Peso por Atado (Kg)	Secção (cm ²)	I - Momento de Inércia (cm ⁴)	W - Momento de Flexão Elástico (cm ³)	i - Raio de Giração (cm)
220	4,5	30,041	9	1622	38,27	2941,55	267,41	8,77
220	5,0	33,250	9	1796	42,36	3238,02	294,37	8,74
220	6,0	39,590	9	2138	50,43	3813,36	346,67	8,70
220	6,3	41,204	9	2225	52,49	3939,93	358,18	8,66
220	8,0	51,529	9	2783	65,64	4828,01	438,91	8,58
220	10,0	63,245	6	2277	80,57	5782,46	525,68	8,47
220	12,0	73,523	6	2647	93,66	6486,85	589,71	8,32
220	12,5	76,179	6	2742	97,04	6673,98	606,73	8,29
250	5,0	37,960	6	1367	48,36	4805,01	384,40	9,97
250	6,0	45,242	6	1629	57,63	5672,00	453,76	9,92
250	6,3	47,139	6	1697	60,05	5872,62	469,81	9,89
250	7,0	52,091	6	1875	66,36	6442,58	515,41	9,85
250	8,0	59,065	6	2126	75,24	7229,20	578,34	9,80
250	10,0	72,665	6	2616	92,57	8706,67	696,53	9,70
250	12,0	84,827	4	2036	108,06	9859,42	788,75	9,55
250	12,5	87,954	4	2111	112,04	10161,31	812,91	9,52
260	5,0	39,530	6	1423	50,36	5422,03	417,08	10,38
260	6,0	47,126	6	1697	60,03	6404,54	492,66	10,33
260	6,3	49,117	6	1768	62,57	6634,95	510,38	10,30
260	8,0	61,577	6	2217	78,44	8178,02	629,08	10,21
260	10,0	75,805	6	2729	96,57	9864,65	758,82	10,11
260	12,0	88,595	4	2126	112,86	11199,50	861,50	9,96
260	12,5	91,879	4	2205	117,04	11547,88	888,30	9,93

Perfis Ocos Rectangulares

EN 10219 - 3

Dimensões	Espessura (mm)	Massa Linear (Kg/m)	Tubos por Atado	Peso por Atado (Kg)	Secção (cm ²)	I _{xx} (cm ⁴)	W _{xx} (cm ³)	i _{xx} (cm)	I _{yy} (cm ⁴)	W _{yy} (cm ³)	i _{yy} (cm)		
20	x	10	1,50	0,590	300	1062,00	0,75	0,325	0,325	0,658	0,105	0,211	0,374
20	x	10	2,00	0,736	300	1324,80	0,94	0,367	0,367	0,626	0,116	0,232	0,352
20	x	15	1,50	0,708	234	994,03	0,90	0,454	0,454	0,710	0,288	0,384	0,565
20	x	15	2,00	0,893	234	1253,77	1,14	0,529	0,529	0,682	0,333	0,444	0,541
25	x	10	1,50	0,708	250	1062,00	0,90	0,595	0,476	0,812	0,133	0,265	0,384
25	x	10	2,00	0,893	250	1339,50	1,14	0,688	0,550	0,778	0,149	0,298	0,362
25	x	13	1,50	0,779	209	976,87	0,99	0,719	0,575	0,851	0,252	0,388	0,504

Perfis Ocos Rectangulares

EN 10219 - 3

Dimensões			Espessura (mm)	Massa Linear (Kg/m)	Tubos por Atado	Peso por Atado (Kg)	Secção (cm ²)	Ixx (cm ⁴)	Wxx (cm ³)	ixx (cm)	Iyy (cm ⁴)	Wyy (cm ³)	iyy (cm)
25	x	13	2,00	0,987	209	1237,70	1,26	0,847	0,678	0,821	0,292	0,449	0,482
25	x	15	1,50	0,826	209	1035,80	1,05	0,802	0,642	0,873	0,356	0,475	0,582
25	x	15	2,00	1,050	209	1316,70	1,34	0,953	0,763	0,844	0,418	0,558	0,559
25	x	20	1,50	0,944	180	1019,52	1,20	1,009	0,807	0,916	0,711	0,711	0,769
25	x	20	2,00	1,207	180	1303,56	1,54	1,218	0,975	0,890	0,855	0,855	0,746
30	x	10	1,50	0,826	225	1115,10	1,05	0,976	0,651	0,963	0,160	0,320	0,390
30	x	10	2,00	1,050	225	1417,50	1,34	1,151	0,768	0,928	0,182	0,363	0,368
30	x	15	1,50	0,944	200	1132,80	1,20	1,281	0,854	1,032	0,425	0,567	0,595
30	x	15	2,00	1,207	200	1448,40	1,54	1,544	1,029	1,002	0,503	0,671	0,572
30	x	20	1,50	1,061	180	1145,88	1,35	1,586	1,057	1,083	0,840	0,840	0,788
30	x	20	2,00	1,364	180	1473,12	1,74	1,937	1,291	1,056	1,017	1,017	0,765
30	x	20	3,0	1,890	180	2041,20	2,41	2,406	1,604	1,000	1,247	1,247	0,720
30	x	25	1,50	1,179	168	1188,43	1,50	1,891	1,261	1,122	1,424	1,139	0,974
30	x	25	2,00	1,521	168	1533,17	1,94	2,329	1,553	1,097	1,749	1,399	0,950
32	x	13	1,50	0,944	200	1132,80	1,20	1,374	0,859	1,069	0,322	0,495	0,517
32	x	13	2,00	1,207	200	1448,40	1,54	1,652	1,033	1,037	0,378	0,581	0,496
35	x	10	1,50	0,944	203	1149,79	1,20	1,490	0,851	1,113	0,187	0,375	0,395
35	x	10	2,00	1,207	203	1470,13	1,54	1,782	1,018	1,077	0,214	0,428	0,373
35	x	15	1,50	1,061	207	1317,76	1,35	1,911	1,092	1,189	0,494	0,658	0,604
35	x	15	2,00	1,364	207	1694,09	1,74	2,327	1,330	1,157	0,589	0,785	0,582
35	x	20	1,50	1,179	160	1131,84	1,50	2,332	1,333	1,246	0,969	0,969	0,803
35	x	20	2,00	1,521	160	1460,16	1,94	2,872	1,641	1,218	1,180	1,180	0,781
35	x	25	1,50	1,297	162	1260,68	1,65	2,753	1,573	1,291	1,631	1,305	0,994
35	x	25	2,00	1,678	162	1631,02	2,14	3,417	1,953	1,265	2,014	1,611	0,971
35	x	25	3,0	2,361	168	2379,89	3,01	4,408	2,519	1,210	2,571	2,057	0,925
40	x	10	1,50	1,061	196	1247,74	1,35	2,153	1,077	1,262	0,215	0,430	0,399
40	x	10	2,00	1,364	196	1604,06	1,74	2,604	1,302	1,224	0,247	0,494	0,377
40	x	15	1,50	1,179	176	1245,02	1,50	2,710	1,355	1,343	0,562	0,750	0,612
40	x	15	2,00	1,521	176	1606,18	1,94	3,327	1,663	1,311	0,674	0,898	0,590
40	x	20	1,50	1,297	162	1260,68	1,65	3,266	1,633	1,406	1,097	1,097	0,815
40	x	20	2,0	1,678	162	1631,02	2,14	4,050	2,025	1,377	1,343	1,343	0,793
40	x	20	2,5	2,032	162	1975,10	2,59	4,694	2,347	1,347	1,537	1,537	0,770
40	x	20	3,0	2,361	162	2294,89	3,01	5,208	2,604	1,316	1,685	1,685	0,748
40	x	25	1,50	1,415	135	1146,15	1,80	3,822	1,911	1,456	1,839	1,471	1,010
40	x	25	2,00	1,835	135	1486,35	2,34	4,772	2,386	1,429	2,279	1,823	0,988
40	x	25	3,0	2,597	135	2103,57	3,31	6,237	3,118	1,373	2,937	2,349	0,942
40	x	27	1,50	1,462	130	1140,36	1,86	4,044	2,022	1,474	2,197	1,628	1,086
40	x	27	2,00	1,897	130	1479,66	2,42	5,061	2,531	1,447	2,734	2,025	1,064
40	x	27	3,0	2,691	130	2098,98	3,43	6,648	3,324	1,393	3,551	2,630	1,018

Perfis Ocos Rectangulares

EN 10219 - 3

Dimensões			Espessura (mm)	Massa Linear (Kg/m)	Tubos por Atado	Peso por Atado (Kg)	Secção (cm ²)	Ixx (cm ⁴)	Wxx (cm ³)	Iyy (cm ⁴)	Wyy (cm ³)	Iyy (cm ⁴)	
40	x	30	1,50	1,532	130	1194,96	1,95	4,378	2,189	1,498	2,806	1,870	1,199
40	x	30	2,00	1,992	130	1553,76	2,54	5,495	2,747	1,472	3,507	2,338	1,176
40	x	30	3,0	2,832	130	2208,96	3,61	7,266	3,633	1,419	4,602	3,068	1,129
40	x	30	4,0	3,570	130	2784,60	4,55	8,472	4,236	1,365	5,330	3,553	1,083
45	x	10	1,50	1,179	162	1145,99	1,50	2,986	1,327	1,410	0,242	0,484	0,402
45	x	10	2,00	1,521	162	1478,41	1,94	3,644	1,619	1,372	0,280	0,559	0,380
45	x	15	1,50	1,297	147	1143,95	1,65	3,696	1,643	1,496	0,631	0,841	0,618
45	x	15	2,00	1,678	147	1480,00	2,14	4,569	2,031	1,462	0,759	1,012	0,596
45	x	20	1,50	1,415	144	1222,56	1,80	4,406	1,958	1,564	1,226	1,226	0,825
45	x	20	2,00	1,835	144	1585,44	2,34	5,494	2,442	1,533	1,505	1,505	0,803
45	x	20	3,0	2,597	144	2243,81	3,31	7,154	3,179	1,470	1,904	1,904	0,759
45	x	25	1,5	1,532	126	1158,19	1,95	5,116	2,274	1,619	2,046	1,637	1,024
45	x	25	2,0	1,992	126	1505,95	2,54	6,419	2,853	1,591	2,544	2,035	1,001
45	x	25	3,0	2,832	126	2140,99	3,61	8,479	3,768	1,533	3,302	2,642	0,957
45	x	30	3,0	3,068	128	2356,22	3,91	9,804	4,357	1,584	5,151	3,434	1,148
45	x	35	1,50	1,768	120	1272,96	2,25	6,535	2,905	1,704	4,438	2,536	1,404
45	x	35	2,00	2,306	120	1660,32	2,94	8,270	3,675	1,678	5,598	3,199	1,381
45	x	35	3,0	3,303	120	2378,16	4,21	11,129	4,946	1,626	7,489	4,279	1,334
45	x	35	4,0	4,198	108	2720,30	5,35	13,238	5,884	1,573	8,859	5,063	1,287
50	x	10	1,50	1,297	144	1120,61	1,65	4,006	1,603	1,557	0,270	0,539	0,404
50	x	10	2,00	1,678	144	1449,79	2,14	4,926	1,970	1,518	0,312	0,624	0,382
50	x	14	1,50	1,391	132	1101,67	1,77	4,712	1,885	1,631	0,596	0,851	0,580
50	x	14	2,00	1,803	132	1427,98	2,30	5,848	2,339	1,596	0,715	1,022	0,558
50	x	15	1,50	1,415	132	1120,68	1,80	4,889	1,956	1,647	0,699	0,933	0,623
50	x	15	2,00	1,835	132	1453,32	2,34	6,078	2,431	1,613	0,844	1,126	0,601
50	x	20	1,50	1,532	126	1158,19	1,95	5,771	2,308	1,719	1,354	1,354	0,833
50	x	20	2,00	1,992	126	1505,95	2,54	7,231	2,892	1,688	1,668	1,668	0,811
50	x	20	3,0	2,832	126	2140,99	3,61	9,513	3,805	1,624	2,123	2,123	0,767
50	x	25	1,50	1,650	128	1267,20	2,10	6,654	2,661	1,779	2,254	1,803	1,035
50	x	25	2,00	2,149	128	1650,43	2,74	8,384	3,353	1,750	2,809	2,247	1,013
50	x	25	3,0	3,068	128	2356,22	3,91	11,172	4,469	1,691	3,667	2,934	0,969
50	x	25	4,00	3,884	128	2982,91	4,95	13,129	5,252	1,629	4,228	3,383	0,924
50	x	27	1,50	1,697	128	1303,30	2,16	7,006	2,803	1,800	2,686	1,989	1,115
50	x	27	2,00	2,211	128	1698,05	2,82	8,845	3,538	1,772	3,360	2,489	1,092
50	x	27	3,00	3,162	120	2276,64	4,03	11,836	4,734	1,714	4,420	3,274	1,047
50	x	27	4,00	4,010	120	2887,20	5,11	13,978	5,591	1,654	5,137	3,805	1,003
50	x	30	1,50	1,768	120	1272,96	2,25	7,536	3,014	1,829	3,415	2,277	1,231
50	x	30	2,0	2,306	120	1660,32	2,94	9,536	3,815	1,802	4,293	2,862	1,209
50	x	30	2,5	2,817	120	2028,24	3,59	11,298	4,519	1,774	5,052	3,368	1,186

Perfis Ocos Rectangulares

EN 10219 - 3

Dimensões			Espessura (mm)	Massa Linear (Kg/m)	Tubos por Atado	Peso por Atado (Kg)	Secção (cm ²)	Ixx (cm ⁴)	Wxx (cm ³)	ixx (cm)	Iyy (cm ⁴)	Wyy (cm ³)	iyy (cm)
50	x	30	3,0	3,303	120	2378,16	4,21	12,831	5,132	1,746	5,700	3,800	1,164
50	x	30	4,0	4,198	108	2720,30	5,35	15,251	6,100	1,689	6,693	4,462	1,119
50	x	30	5,0	4,990	108	3233,52	6,36	16,871	6,748	1,629	7,325	4,884	1,074
50	x	35	1,5	1,886	108	1222,13	2,40	8,418	3,367	1,872	4,859	2,776	1,422
50	x	35	2,0	2,463	108	1596,02	3,14	10,689	4,276	1,846	6,143	3,510	1,399
50	x	35	3,0	3,539	108	2293,27	4,51	14,490	5,796	1,793	8,259	4,719	1,354
50	x	40	1,5	2,003	99	1189,78	2,55	9,301	3,720	1,909	6,602	3,301	1,608
50	x	40	2,0	2,620	99	1556,28	3,34	11,842	4,737	1,884	8,386	4,193	1,585
50	x	40	3,0	3,774	99	2241,76	4,81	16,149	6,460	1,833	11,382	5,691	1,539
50	x	40	4,0	4,826	88	2548,13	6,15	19,493	7,797	1,781	13,677	6,839	1,492
55	x	35	1,50	2,003	96	1153,73	2,55	10,601	3,855	2,038	5,280	3,017	1,438
55	x	35	2,00	2,620	96	1509,12	3,34	13,500	4,909	2,011	6,688	3,822	1,416
55	x	35	3,00	3,774	96	2173,82	4,81	18,414	6,696	1,957	9,029	5,160	1,370
55	x	35	4,00	4,826	96	2779,78	6,15	22,224	8,081	1,901	10,792	6,167	1,325
55	x	45	1,50	2,239	99	1329,97	2,85	12,749	4,636	2,114	9,375	4,167	1,813
55	x	45	2,00	2,934	99	1742,80	3,74	16,311	5,931	2,089	11,970	5,320	1,790
55	x	45	3,00	4,245	99	2521,53	5,41	22,475	8,173	2,039	16,430	7,302	1,743
55	x	45	4,00	5,454	63	2061,61	6,95	27,437	9,977	1,987	19,984	8,882	1,696
60	x	10	1,50	1,532	100	919,20	1,95	6,685	2,228	1,851	0,324	0,649	0,408
60	x	10	2,00	1,992	100	1195,20	2,54	8,316	2,772	1,810	0,378	0,755	0,386
60	x	15	1,50	1,650	100	990,00	2,10	7,969	2,656	1,947	0,837	1,116	0,631
60	x	15	2,00	2,149	100	1289,40	2,74	9,998	3,333	1,911	1,014	1,353	0,609
60	x	15	3,00	3,068	100	1840,80	3,91	13,184	4,395	1,837	1,250	1,666	0,566
60	x	20	1,50	1,768	108	1145,66	2,25	9,253	3,084	2,027	1,612	1,612	0,846
60	x	20	2,00	2,306	108	1494,29	2,94	11,681	3,894	1,994	1,993	1,993	0,824
60	x	20	3,0	3,303	108	2140,34	4,21	15,623	5,208	1,927	2,561	2,561	0,780
60	x	25	1,50	1,886	105	1188,18	2,40	10,536	3,512	2,094	2,668	2,135	1,054
60	x	25	2,00	2,463	105	1551,69	3,14	13,364	4,455	2,064	3,340	2,672	1,032
60	x	25	3,0	3,539	105	2229,57	4,51	18,062	6,021	2,002	4,398	3,518	0,988
60	x	30	1,50	2,003	98	1177,76	2,55	11,820	3,940	2,152	4,025	2,683	1,256
60	x	30	2,00	2,620	98	1540,56	3,34	15,046	5,015	2,123	5,078	3,385	1,234
60	x	30	3,0	3,774	98	2219,11	4,81	20,501	6,834	2,065	6,798	4,532	1,189
60	x	30	4,0	4,826	88	2548,13	6,15	24,703	8,234	2,005	8,055	5,370	1,145
60	x	40	1,50	2,239	88	1182,19	2,85	14,387	4,796	2,246	7,715	3,857	1,645
60	x	40	2,0	2,934	88	1549,15	3,74	18,412	6,137	2,220	9,831	4,915	1,622
60	x	40	2,5	3,602	88	1901,86	4,59	22,071	7,357	2,193	11,736	5,868	1,599
60	x	40	3,0	4,245	88	2241,36	5,41	25,379	8,460	2,166	13,440	6,720	1,576
60	x	40	4,0	5,454	54	1767,10	6,95	30,986	10,329	2,112	16,280	8,140	1,531
60	x	40	5,0	6,560	48	1889,28	8,36	35,328	11,776	2,056	18,426	9,213	1,485

Perfis Ocos Rectangulares

EN 10219 - 3

Dimensões			Espessura (mm)	Massa Linear (Kg/m)	Tubos por Atado	Peso por Atado (Kg)	Secção (cm ²)	Ixx (cm ⁴)	Wxx (cm ³)	ixx (cm)	Iyy (cm ⁴)	Wyy (cm ³)	Iyy (cm)
60	x	40	6,0	7,562	48	2177,86	9,63	38,497	12,832	1,999	19,948	9,974	1,439
60	x	50	1,50	2,474	72	1068,77	3,15	16,954	5,651	2,319	12,830	5,132	2,018
60	x	50	2,00	3,248	72	1403,14	4,14	21,777	7,259	2,294	16,452	6,581	1,994
60	x	50	3,0	4,716	48	1358,21	6,01	30,257	10,086	2,244	22,785	9,114	1,947
60	x	50	4,0	6,082	48	1751,62	7,75	37,268	12,423	2,193	27,979	11,191	1,900
63,5	x	31,8	5,0	6,191	48	1783,01	7,89	33,937	10,689	2,074	10,972	6,900	1,180
70	x	20	1,50	2,003	98	1177,76	2,55	13,860	3,960	2,330	1,869	1,869	0,856
70	x	20	2,00	2,620	98	1540,56	3,34	17,599	5,028	2,297	2,319	2,319	0,834
70	x	20	3,0	3,774	98	2219,11	4,81	23,837	6,810	2,227	2,999	2,999	0,790
70	x	30	1,50	2,239	84	1128,46	2,85	17,380	4,966	2,469	4,635	3,090	1,275
70	x	30	2,00	2,934	84	1478,74	3,74	22,225	6,350	2,439	5,863	3,909	1,253
70	x	30	3,0	4,245	84	2139,48	5,41	30,575	8,736	2,378	7,896	5,264	1,208
70	x	30	4,0	5,454	54	1767,10	6,95	37,230	10,637	2,315	9,418	6,279	1,164
70	x	35	5,0	6,952	40	1668,48	8,86	47,588	13,596	2,318	15,447	8,827	1,321
70	x	40	1,50	2,474	72	1068,77	3,15	20,900	5,971	2,575	8,827	4,413	1,673
70	x	40	2,00	3,248	72	1403,14	4,14	26,850	7,671	2,548	11,276	5,638	1,651
70	x	40	3,0	4,716	72	2037,31	6,01	37,313	10,661	2,492	15,498	7,749	1,606
70	x	40	4,0	6,082	54	1970,57	7,75	45,952	13,129	2,435	18,883	9,441	1,561
70	x	40	5,0	7,345	42	1850,94	9,36	52,879	15,108	2,377	21,509	10,755	1,516
70	x	40	6,0	8,504	42	2143,01	10,83	58,201	16,629	2,318	23,452	11,726	1,471
70	x	50	1,5	2,710	63	1024,38	3,45	24,420	6,977	2,660	14,595	5,838	2,056
70	x	50	2,0	3,562	63	1346,44	4,54	31,475	8,993	2,634	18,758	7,503	2,033
70	x	50	2,5	4,387	63	1658,29	5,59	38,014	10,861	2,608	22,590	9,036	2,010
70	x	50	3,0	5,187	35	1089,27	6,61	44,051	12,586	2,582	26,103	10,441	1,987
70	x	50	4,0	6,710	35	1409,10	8,55	54,675	15,621	2,529	32,221	12,888	1,942
70	x	50	5,0	8,130	35	1707,30	10,36	63,463	18,132	2,475	37,204	14,882	1,895
70	x	50	6,0	9,446	35	1983,66	12,03	70,525	20,150	2,421	41,142	16,457	1,849
70	x	50	8,0	11,337	35	2380,77	14,44	73,183	20,909	2,251	42,868	17,147	1,723
70	x	60	1,5	2,945	54	954,18	3,75	27,939	7,983	2,729	22,089	7,363	2,426
70	x	60	2,0	3,876	54	1255,82	4,94	36,101	10,314	2,704	28,508	9,503	2,403
70	x	60	3,0	5,658	54	1833,19	7,21	50,789	14,511	2,654	40,013	13,338	2,356
70	x	60	4,0	7,338	54	2377,51	9,35	63,398	18,114	2,604	49,834	16,611	2,309
80	x	20	1,5	2,239	68	913,51	2,85	19,744	4,936	2,631	2,126	2,126	0,863
80	x	20	2,0	2,934	68	1197,07	3,74	25,186	6,297	2,596	2,644	2,644	0,841
80	x	20	3,0	4,245	68	1731,96	5,41	34,455	8,614	2,524	3,437	3,437	0,797
80	x	25	3,0	4,481	68	1828,25	5,71	38,904	9,726	2,611	5,859	4,687	1,013
80	x	30	1,5	2,474	72	1068,77	3,15	24,366	6,092	2,780	5,245	3,496	1,290
80	x	30	2,0	3,248	72	1403,14	4,14	31,272	7,818	2,749	6,649	4,432	1,268
80	x	30	3,0	4,716	72	2037,31	6,01	43,353	10,838	2,686	8,994	5,996	1,224

Perfis Ocos Rectangulares

EN 10219 - 3

Dimensões			Espessura (mm)	Massa Linear (Kg/m)	Tubos por Atado	Peso por Atado (Kg)	Secção (cm ²)	Ixx (cm ⁴)	Wxx (cm ³)	Iyy (cm ⁴)	Iyy (cm ⁴)	Wyy (cm ³)	Iyy (cm ⁴)
80	x	30	4,0	6,082	50	1824,60	7,75	53,230	13,308	2,621	10,781	7,187	1,180
80	x	40	1,5	2,710	72	1170,72	3,45	28,988	7,247	2,898	9,939	4,970	1,697
80	x	40	2,0	3,562	72	1538,78	4,54	37,357	9,339	2,869	12,722	6,361	1,675
80	x	40	2,5	4,387	72	1895,18	5,59	45,106	11,276	2,841	15,257	7,628	1,652
80	x	40	3,0	5,187	72	2240,78	6,61	52,251	13,063	2,812	17,556	8,778	1,630
80	x	40	4,0	6,710	50	2013,00	8,55	64,793	16,198	2,753	21,485	10,743	1,585
80	x	40	5,0	8,130	35	1707,30	10,36	75,109	18,777	2,693	24,593	12,296	1,541
80	x	40	6,0	9,446	35	1983,66	12,03	83,321	20,830	2,631	26,956	13,478	1,497
80	x	40	8,0	11,337	35	2380,77	14,44	85,092	21,273	2,427	27,663	13,832	1,384
80	x	50	1,5	2,945	60	1060,20	3,75	33,611	8,403	2,993	16,360	6,544	2,088
80	x	50	2,0	3,876	60	1395,36	4,94	43,442	10,861	2,966	21,063	8,425	2,066
80	x	50	3,0	5,658	60	2036,88	7,21	61,149	15,287	2,913	29,421	11,768	2,020
80	x	50	4,0	7,338	42	1849,18	9,35	76,355	19,089	2,858	36,464	14,586	1,975
80	x	50	5,0	8,915	16	855,84	11,36	89,192	22,298	2,803	42,288	16,915	1,930
80	x	50	6,0	10,388	16	997,25	13,23	99,785	24,946	2,746	46,986	18,795	1,884
80	x	60	1,5	3,181	42	801,61	4,05	38,233	9,558	3,072	24,656	8,219	2,467
80	x	60	2,0	4,190	42	1055,88	5,34	49,528	12,382	3,046	31,873	10,624	2,444
80	x	60	2,5	5,172	42	1303,34	6,59	60,126	15,032	3,021	38,613	12,871	2,421
80	x	60	3,0	6,129	42	1544,51	7,81	70,047	17,512	2,995	44,891	14,964	2,398
80	x	60	4,0	7,966	42	2007,43	10,15	87,918	21,980	2,943	56,116	18,705	2,352
80	x	60	5,0	9,700	30	1746,00	12,36	103,275	25,819	2,891	65,661	21,887	2,305
80	x	60	6,0	11,330	24	1631,52	14,43	116,249	29,062	2,838	73,633	24,544	2,259
80	x	60	8,0	13,849	24	1994,26	17,64	126,734	31,684	2,680	80,378	26,793	2,134
90	x	30	3,0	5,187	55	1711,71	6,61	59,135	13,141	2,991	10,092	6,728	1,236
90	x	30	4,0	6,710	45	1811,70	8,55	73,105	16,245	2,924	12,143	8,096	1,192
90	x	40	1,5	2,945	50	883,50	3,75	38,803	8,623	3,216	11,051	5,526	1,716
90	x	40	2,0	3,876	50	1162,80	4,94	50,132	11,141	3,187	14,167	7,083	1,694
90	x	40	3,0	5,658	50	1697,40	7,21	70,493	15,665	3,127	19,614	9,807	1,650
90	x	40	4,0	7,338	50	2201,40	9,35	87,907	19,535	3,067	24,088	12,044	1,605
90	x	50	1,5	3,181	45	858,87	4,05	44,678	9,928	3,321	18,124	7,250	2,115
90	x	50	2,0	4,190	45	1131,30	5,34	57,878	12,862	3,293	23,368	9,347	2,092
90	x	50	2,5	5,172	45	1396,44	6,59	70,262	15,614	3,266	28,236	11,294	2,070
90	x	50	3,0	6,129	45	1654,83	7,81	81,851	18,189	3,238	32,739	13,096	2,048
90	x	50	4,0	7,966	40	1911,84	10,15	102,710	22,824	3,181	40,707	16,283	2,003
90	x	50	5,0	9,700	40	2328,00	12,36	120,600	26,800	3,124	47,371	18,948	1,958
90	x	50	6,0	11,330	35	2379,30	14,43	135,661	30,147	3,066	52,830	21,132	1,913
90	x	50	6,3	11,531	35	2421,51	14,69	132,694	29,488	3,006	52,129	20,852	1,884
90	x	50	8,0	13,849	35	2908,29	17,64	146,665	32,592	2,883	57,151	22,860	1,800
95	x	25	1,5	2,710	60	975,60	3,45	34,569	7,278	3,164	4,120	3,296	1,092

Perfis Ocos Rectangulares

EN 10219 - 3

Dimensões			Espessura (mm)	Massa Linear (Kg/m)	Tubos por Atado	Peso por Atado (Kg)	Secção (cm²)	Ixx (cm⁴)	Wxx (cm³)	ixx (cm)	Iyy (cm⁴)	Wyy (cm³)	Iyy (cm)
95	x	25	2,0	3,562	60	1282,32	4,54	44,458	9,360	3,130	5,196	4,157	1,070
95	x	25	3,0	5,187	60	1867,32	6,61	61,896	13,031	3,060	6,954	5,564	1,026
100	x	20	1,5	2,710	80	1300,80	3,45	35,939	7,188	3,227	2,641	2,641	0,875
100	x	20	2,0	3,562	80	1709,76	4,54	46,166	9,233	3,190	3,295	3,295	0,852
100	x	20	3,0	5,187	80	2489,76	6,61	64,103	12,821	3,115	4,313	4,313	0,808
100	x	30	1,5	2,945	50	883,50	3,75	43,216	8,643	3,394	6,464	4,309	1,313
100	x	30	2,0	3,876	50	1162,80	4,94	55,771	11,154	3,361	8,219	5,480	1,290
100	x	30	3,0	5,658	50	1697,40	7,21	78,221	15,644	3,294	11,190	7,460	1,246
100	x	30	4,0	7,338	30	1320,84	9,35	97,253	19,451	3,225	13,506	9,004	1,202
100	x	40	1,5	3,181	55	1049,73	4,05	50,494	10,099	3,530	12,164	6,082	1,733
100	x	40	2,0	4,190	55	1382,70	5,34	65,376	13,075	3,500	15,612	7,806	1,710
100	x	40	2,5	5,172	55	1706,76	6,59	79,318	15,864	3,470	18,778	9,389	1,688
100	x	40	3,0	6,129	55	2022,57	7,81	92,339	18,468	3,439	21,672	10,836	1,666
100	x	40	4,0	7,966	40	1911,84	10,15	115,696	23,139	3,377	26,691	13,345	1,622
100	x	40	5,0	9,700	36	2095,20	12,36	135,602	27,120	3,313	30,759	15,380	1,578
100	x	40	6,0	11,330	32	2175,36	14,43	152,210	30,442	3,247	33,964	16,982	1,534
100	x	50	1,5	3,416	50	1024,80	4,35	57,771	11,554	3,643	19,889	7,956	2,138
100	x	50	2,0	4,504	50	1351,20	5,74	74,982	14,996	3,615	25,674	10,269	2,115
100	x	50	2,5	5,565	50	1669,50	7,09	91,203	18,241	3,587	31,058	12,423	2,093
100	x	50	3,0	6,600	50	1980,00	8,41	106,457	21,291	3,558	36,057	14,423	2,071
100	x	50	4,0	8,594	36	1856,30	10,95	134,138	26,828	3,500	44,949	17,980	2,026
100	x	50	5,0	10,485	28	1761,48	13,36	158,185	31,637	3,441	52,454	20,982	1,982
100	x	50	6,0	12,272	24	1767,17	15,63	178,754	35,751	3,381	58,674	23,470	1,937
100	x	50	6,3	12,520	24	1802,88	15,95	175,680	35,136	3,319	58,186	23,275	1,910
100	x	50	8,0	15,105	24	2175,12	19,24	196,237	39,247	3,193	64,292	25,717	1,828
100	x	60	1,5	3,652	35	766,92	4,65	65,048	13,010	3,739	29,791	9,930	2,531
100	x	60	2,0	4,818	35	1011,78	6,14	84,587	16,917	3,713	38,604	12,868	2,508
100	x	60	2,5	5,957	35	1250,97	7,59	103,089	20,618	3,686	46,884	15,628	2,486
100	x	60	3,0	7,071	35	1484,91	9,01	120,575	24,115	3,659	54,647	18,216	2,463
100	x	60	4,0	9,222	35	1936,62	11,75	152,581	30,516	3,604	68,682	22,894	2,418
100	x	60	5,0	11,270	28	1893,36	14,36	180,769	36,154	3,548	80,828	26,943	2,373
100	x	60	6,0	13,214	24	1902,82	16,83	205,298	41,060	3,492	91,201	30,400	2,328
100	x	60	6,3	13,510	24	1945,44	17,21	203,378	40,676	3,438	90,913	30,304	2,298
100	x	60	7,0	14,725	20	1767,00	18,76	215,727	43,145	3,391	96,138	32,046	2,264
100	x	60	8,0	16,361	12	1177,99	20,84	230,179	46,036	3,323	102,180	34,060	2,214
100	x	70	2,0	5,132	24	739,01	6,54	94,192	18,838	3,796	54,602	15,601	2,890
100	x	70	3,0	7,542	24	1086,05	9,61	134,693	26,939	3,744	77,741	22,212	2,844
100	x	70	4,0	9,850	24	1418,40	12,55	171,024	34,205	3,692	98,288	28,082	2,799
100	x	70	5,0	12,055	24	1735,92	15,36	203,352	40,670	3,639	116,379	33,251	2,753

Perfis Ocos Rectangulares

EN 10219 - 3

Dimensões		Espessura (mm)		Massa Linear (Kg/m)	Tubos por Atado	Peso por Atado (Kg)	Secção (cm ²)	Ixx (cm ⁴)	Wxx (cm ³)	ixx (cm)	Iyy (cm ⁴)	Wyy (cm ³)	iyy (cm)
100	x	70	6,0	14,156	24	2038,46	18,03	231,842	46,368	3,586	132,145	37,756	2,707
100	x	70	8,0	17,617	24	2536,85	22,44	264,120	52,824	3,431	150,489	42,997	2,590
100	x	80	2,0	5,446	35	1143,66	6,94	103,798	20,760	3,868	73,869	18,467	3,263
100	x	80	2,5	6,742	35	1415,82	8,59	126,860	25,372	3,843	90,168	22,542	3,240
100	x	80	3,0	8,013	30	1442,34	10,21	148,811	29,762	3,818	105,639	26,410	3,217
100	x	80	4,0	10,478	30	1886,04	13,35	189,466	37,893	3,768	134,169	33,542	3,170
100	x	80	5,0	12,840	25	1926,00	16,36	225,935	45,187	3,717	159,609	39,902	3,124
100	x	80	6,0	15,098	20	1811,76	19,23	258,386	51,677	3,665	182,105	45,526	3,077
100	x	80	6,3	15,488	20	1858,56	19,73	258,773	51,755	3,622	182,811	45,703	3,044
100	x	80	7,0	16,923	20	2030,76	21,56	276,384	55,277	3,581	195,032	48,758	3,008
100	x	80	8,0	18,873	12	1358,86	24,04	298,061	59,612	3,521	210,020	52,505	2,956
101,6	x	76,2	6,0	14,891	9	804,11	18,97	258,289	50,844	3,690	164,391	43,147	2,944
120	x	40	1,5	3,652	48	1051,78	4,65	80,103	13,351	4,150	14,388	7,194	1,759
120	x	40	2,0	4,818	48	1387,58	6,14	104,070	17,345	4,118	18,503	9,251	1,736
120	x	40	3,0	7,071	30	1272,78	9,01	148,043	24,674	4,054	25,788	12,894	1,692
120	x	40	4,0	9,222	30	1659,96	11,75	186,895	31,149	3,989	31,896	15,948	1,648
120	x	40	5,0	11,270	30	2028,60	14,36	220,808	36,801	3,922	36,926	18,463	1,604
120	x	40	6,0	13,214	30	2378,52	16,83	249,965	41,661	3,854	40,972	20,486	1,560
120	x	50	2,0	5,132	32	985,34	6,54	117,995	19,666	4,249	30,284	12,114	2,152
120	x	50	3,0	7,542	32	1448,06	9,61	168,581	28,097	4,189	42,693	17,077	2,108
120	x	50	4,0	9,850	32	1891,20	12,55	213,817	35,636	4,128	53,435	21,374	2,064
120	x	50	5,0	12,055	24	1735,92	15,36	253,891	42,315	4,066	62,621	25,048	2,019
120	x	50	6,0	14,156	24	2038,46	18,03	288,989	48,165	4,003	70,362	28,145	1,975
120	x	50	8,0	17,617	24	2536,85	22,44	325,047	54,174	3,806	78,575	31,430	1,871
120	x	60	2,0	5,446	32	1045,63	6,94	131,920	21,987	4,361	45,334	15,111	2,556
120	x	60	2,5	6,742	32	1294,46	8,59	161,229	26,872	4,333	55,155	18,385	2,534
120	x	60	3,0	8,013	32	1538,50	10,21	189,119	31,520	4,304	64,403	21,468	2,512
120	x	60	4,0	10,478	32	2011,78	13,35	240,740	40,123	4,247	81,247	27,082	2,467
120	x	60	5,0	12,840	24	1848,96	16,36	286,975	47,829	4,189	95,994	31,998	2,423
120	x	60	6,0	15,098	20	1811,76	19,23	328,013	54,669	4,130	108,769	36,256	2,378
120	x	60	6,3	15,488	20	1858,56	19,73	326,969	54,495	4,071	109,164	36,388	2,352
120	x	60	7,0	16,923	16	1624,61	21,56	348,771	58,129	4,022	115,915	38,638	2,319
120	x	60	8,0	18,873	16	1811,81	24,04	375,308	62,551	3,951	123,983	41,328	2,271
120	x	80	2,0	6,074	30	1093,32	7,74	159,771	26,628	4,544	86,040	21,510	3,335
120	x	80	3,0	8,955	30	1611,90	11,41	230,195	38,366	4,492	123,435	30,859	3,289
120	x	80	3,5	10,358	30	1864,44	13,19	263,132	43,855	4,466	140,796	35,199	3,267
120	x	80	4,0	11,734	30	2112,12	14,95	294,585	49,098	4,439	157,294	39,324	3,244
120	x	80	4,5	13,085	30	2355,30	16,67	324,580	54,097	4,413	172,947	43,237	3,221
120	x	80	5,0	14,410	25	2161,50	18,36	353,141	58,857	4,386	187,775	46,944	3,198

Perfis Ocos Rectangulares

EN 10219 - 3

Dimensões			Espessura (mm)	Massa Linear (Kg/m)	Tubos por Atado	Peso por Atado (Kg)	Secção (cm²)	Ixx (cm⁴)	Wxx (cm³)	ixx (cm)	Iyy (cm⁴)	Wyy (cm³)	Iyy (cm)
120	x	80	6,0	16,982	25	2547,30	21,63	406,061	67,677	4,332	215,033	53,758	3,153
120	x	80	6,3	17,466	25	2619,90	22,25	408,497	68,083	4,285	217,114	54,279	3,124
120	x	80	7,0	19,121	16	1835,62	24,36	438,269	73,045	4,242	232,449	58,112	3,089
120	x	80	8,0	21,385	16	2052,96	27,24	475,831	79,305	4,179	251,662	62,916	3,039
120	x	80	10,0	25,565	16	2454,24	32,57	534,142	89,024	4,050	281,145	70,286	2,938
120	x	100	3,0	9,897	25	1484,55	12,61	271,271	45,212	4,638	205,283	41,057	4,035
120	x	100	3,5	11,457	25	1718,55	14,59	310,649	51,775	4,614	234,887	46,977	4,012
120	x	100	4,0	12,990	25	1948,50	16,55	348,431	58,072	4,589	263,237	52,647	3,988
120	x	100	4,5	14,498	20	1739,76	18,47	384,641	64,107	4,564	290,357	58,071	3,965
120	x	100	5,0	15,980	20	1917,60	20,36	419,308	69,885	4,539	316,269	63,254	3,942
120	x	100	6,0	18,866	20	2263,92	24,03	484,109	80,685	4,488	364,562	72,912	3,895
120	x	100	6,3	19,444	20	2333,28	24,77	490,025	81,671	4,448	369,564	73,913	3,863
120	x	100	7,0	21,319	16	2046,62	27,16	527,766	87,961	4,408	397,699	79,540	3,827
120	x	100	8,0	23,897	16	2294,11	30,44	576,353	96,059	4,351	433,827	86,765	3,775
120	x	100	10,0	28,705	16	2755,68	36,57	655,475	109,246	4,234	492,410	98,482	3,670
127	x	76	3,0	9,097	30	1637,46	11,59	254,720	40,113	4,688	115,478	30,389	3,157
127	x	76	4,0	11,923	30	2146,14	15,19	326,168	51,365	4,634	147,060	38,700	3,112
127	x	76	4,5	13,297	30	2393,46	16,94	359,488	56,612	4,607	161,644	42,538	3,089
127	x	76	6,0	17,264	24	2486,02	21,99	450,140	70,888	4,524	200,788	52,839	3,022
127	x	76	6,3	17,763	24	2557,87	22,63	452,783	71,304	4,473	202,867	53,386	2,994
130	x	100	3,0	10,368	20	1244,16	13,21	327,690	50,414	4,981	219,401	43,880	4,076
130	x	100	3,5	12,006	20	1440,72	15,29	375,605	57,785	4,956	251,190	50,238	4,053
130	x	100	4,0	13,618	20	1634,16	17,35	421,681	64,874	4,930	281,680	56,336	4,030
130	x	100	4,5	15,204	20	1824,48	19,37	465,946	71,684	4,905	310,892	62,178	4,006
130	x	100	5,0	16,765	20	2011,80	21,36	508,428	78,220	4,879	338,852	67,770	3,983
130	x	100	6,0	19,808	20	2376,96	25,23	588,152	90,485	4,828	391,106	78,221	3,937
130	x	100	8,0	25,153	20	3018,36	32,04	703,990	108,306	4,687	467,768	93,554	3,821
140	x	50	2,0	5,760	28	967,68	7,34	174,082	24,869	4,871	34,895	13,958	2,181
140	x	50	3,0	8,484	28	1425,31	10,81	249,923	35,703	4,809	49,329	19,732	2,136
140	x	50	3,5	9,808	28	1647,74	12,49	285,140	40,734	4,777	55,847	22,339	2,114
140	x	50	4,0	11,106	28	1865,81	14,15	318,592	45,513	4,745	61,920	24,768	2,092
140	x	50	4,5	12,378	28	2079,50	15,77	350,306	50,044	4,713	67,562	27,025	2,070
140	x	50	5,0	13,625	28	2289,00	17,36	380,309	54,330	4,681	72,788	29,115	2,048
140	x	50	6,0	16,040	28	2694,72	20,43	435,290	62,184	4,616	82,050	32,820	2,004
140	x	60	2,0	6,074	24	874,66	7,74	193,128	27,590	4,996	52,065	17,355	2,594
140	x	60	3,0	8,955	24	1289,52	11,41	278,081	39,726	4,937	74,159	24,720	2,550
140	x	60	3,5	10,358	24	1491,55	13,19	317,753	45,393	4,907	84,282	28,094	2,527
140	x	60	4,0	11,734	24	1689,70	14,95	355,595	50,799	4,877	93,812	31,271	2,505
140	x	60	4,5	13,085	24	1884,24	16,67	391,632	55,947	4,847	102,767	34,256	2,483

Perfis Ocos Rectangulares

EN 10219 - 3

Dimensões			Espessura (mm)	Massa Linear (Kg/m)	Tubos por Atado	Peso por Atado (Kg)	Secção (cm ²)	Ixx (cm ⁴)	Wxx (cm ³)	ixx (cm)	Iyy (cm ⁴)	Wyy (cm ³)	iyy (cm)
140	x	60	6,0	16,982	24	2445,41	21,63	489,194	69,885	4,755	126,337	42,112	2,417
140	x	60	6,3	17,466	24	2515,10	22,25	490,020	70,003	4,693	127,414	42,471	2,393
140	x	60	7,0	19,121	24	2753,42	24,36	524,931	74,990	4,642	135,692	45,231	2,360
140	x	60	8,0	21,385	18	2309,58	27,24	568,522	81,217	4,568	145,786	48,595	2,313
140	x	60	10,0	25,565	18	2761,02	32,57	634,339	90,620	4,413	160,345	53,448	2,219
140	x	70	3,0	9,426	30	1696,68	12,01	306,239	43,748	5,050	104,693	29,912	2,953
140	x	70	3,5	10,907	30	1963,26	13,89	350,367	50,052	5,022	119,314	34,090	2,930
140	x	70	4,0	12,362	25	1854,30	15,75	392,597	56,085	4,993	133,179	38,051	2,908
140	x	70	4,5	13,791	25	2068,65	17,57	432,958	61,851	4,964	146,306	41,802	2,886
140	x	70	5,0	15,195	20	1823,40	19,36	471,476	67,354	4,935	158,713	45,346	2,863
140	x	70	6,0	17,924	20	2150,88	22,83	543,098	77,585	4,877	181,441	51,840	2,819
140	x	70	6,3	18,455	20	2214,60	23,51	546,370	78,053	4,821	183,538	52,440	2,794
140	x	70	7,0	20,220	16	1941,12	25,76	586,899	83,843	4,773	196,340	56,097	2,761
140	x	70	8,0	22,641	12	1630,15	28,84	638,304	91,186	4,704	212,335	60,667	2,713
140	x	70	10,0	27,135	12	1953,72	34,57	719,006	102,715	4,561	236,770	67,649	2,617
140	x	80	3,0	9,897	25	1484,55	12,61	334,397	47,771	5,150	141,231	35,308	3,347
140	x	80	3,5	11,457	25	1718,55	14,59	382,981	54,712	5,123	161,294	40,323	3,324
140	x	80	4,0	12,990	20	1558,80	16,55	429,600	61,371	5,095	180,419	45,105	3,302
140	x	80	4,5	14,498	20	1739,76	18,47	474,283	67,755	5,068	198,629	49,657	3,279
140	x	80	5,0	15,980	20	1917,60	20,36	517,059	73,866	5,040	215,942	53,986	3,257
140	x	80	6,0	18,866	20	2263,92	24,03	597,002	85,286	4,984	247,961	61,990	3,212
140	x	80	6,3	19,444	20	2333,28	24,77	602,720	86,103	4,933	251,417	62,854	3,186
140	x	80	7,0	21,319	16	2046,62	27,16	648,868	92,695	4,888	269,867	67,467	3,152
140	x	80	8,0	23,897	16	2294,11	30,44	708,085	101,155	4,823	293,305	73,326	3,104
140	x	80	10,0	28,705	12	2066,76	36,57	803,673	114,810	4,688	330,478	82,619	3,006
140	x	100	3,0	10,839	20	1300,68	13,81	390,713	55,816	5,319	233,519	46,704	4,112
140	x	100	3,5	12,556	20	1506,72	15,99	448,208	64,030	5,294	267,494	53,499	4,090
140	x	100	4,0	14,246	20	1709,52	18,15	503,605	71,944	5,268	300,122	60,024	4,067
140	x	100	4,5	15,911	20	1909,32	20,27	556,935	79,562	5,242	331,428	66,286	4,044
140	x	100	5,0	17,550	20	2106,00	22,36	608,226	86,889	5,216	361,435	72,287	4,021
140	x	100	6,0	20,750	20	2490,00	26,43	704,810	100,687	5,164	417,650	83,530	3,975
140	x	100	8,0	26,409	16	2535,26	33,64	847,648	121,093	5,020	501,709	100,342	3,862
140	x	100	10,0	31,845	16	3057,12	40,57	973,006	139,001	4,898	573,743	114,749	3,761
140	x	120	3,0	11,781	16	1130,98	15,01	447,029	63,861	5,458	353,423	58,904	4,853
140	x	120	3,5	13,655	16	1310,88	17,39	513,435	73,348	5,433	405,684	67,614	4,829
140	x	120	4,0	15,502	16	1488,19	19,75	577,611	82,516	5,408	456,121	76,020	4,806
140	x	120	4,5	17,324	16	1663,10	22,07	639,586	91,369	5,383	504,764	84,127	4,783
140	x	120	5,0	19,120	16	1835,52	24,36	699,393	99,913	5,359	551,641	91,940	4,759
140	x	120	6,0	22,634	16	2172,86	28,83	812,618	116,088	5,309	640,205	106,701	4,712

Perfis Ocos Rectangulares

EN 10219 - 3

Dimensões			Espessura (mm)	Massa Linear (Kg/m)	Tubos por Atado	Peso por Atado (Kg)	Secção (cm ²)	Ixx (cm ⁴)	Wxx (cm ³)	Iyy (cm ⁴)	Wyy (cm ³)	Iyy (cm ⁴)	
140	x	120	8,0	28,921	16	2776,42	36,84	987,210	141,030	5,176	777,399	129,566	4,594
140	x	120	10,0	34,985	12	2518,92	44,57	1142,339	163,191	5,063	898,142	149,690	4,489
140	x	120	12,0	39,611	12	2851,99	50,46	1201,145	171,592	4,879	946,240	157,707	4,330
140	x	120	12,5	40,854	12	2941,49	52,04	1221,379	174,483	4,844	962,118	160,353	4,300
150	x	50	2,0	6,074	28	1020,43	7,74	207,529	27,670	5,179	37,200	14,880	2,193
150	x	50	3,0	8,955	28	1504,44	11,41	298,549	39,807	5,116	52,647	21,059	2,148
150	x	50	3,5	10,358	28	1740,14	13,19	340,978	45,464	5,084	59,638	23,855	2,126
150	x	50	4,0	11,734	28	1971,31	14,95	381,390	50,852	5,051	66,163	26,465	2,104
150	x	50	4,5	13,085	28	2198,28	16,67	419,817	55,976	5,019	72,235	28,894	2,082
150	x	50	6,0	16,982	24	2445,41	21,63	523,465	69,795	4,919	87,894	35,158	2,016
150	x	50	6,3	17,466	24	2515,10	22,25	522,830	69,711	4,848	88,472	35,389	1,994
150	x	50	7,0	19,121	20	2294,52	24,36	559,300	74,573	4,792	93,752	37,501	1,962
150	x	50	8,0	21,385	20	2566,20	27,24	604,420	80,589	4,710	99,999	40,000	1,916
150	x	50	10,0	25,565	16	2454,24	32,57	670,863	89,448	4,539	108,370	43,348	1,824
150	x	70	3,0	9,897	24	1425,17	12,61	363,385	48,451	5,369	111,431	31,837	2,973
150	x	70	3,5	11,457	24	1649,81	14,59	416,110	55,481	5,340	127,060	36,303	2,951
150	x	70	4,0	12,990	20	1558,80	16,55	466,676	62,223	5,310	141,902	40,543	2,928
150	x	70	4,5	14,498	20	1739,76	18,47	515,113	68,682	5,281	155,974	44,564	2,906
150	x	70	5,0	15,980	20	1917,60	20,36	561,452	74,860	5,252	169,296	48,370	2,884
150	x	70	6,0	18,866	20	2263,92	24,03	647,953	86,394	5,192	193,765	55,361	2,839
150	x	70	6,3	19,444	20	2333,28	24,77	653,006	87,067	5,135	196,362	56,103	2,816
150	x	70	7,0	21,319	16	2046,62	27,16	702,557	93,674	5,086	210,289	60,083	2,783
150	x	70	8,0	23,897	16	2294,11	30,44	765,903	102,120	5,016	227,796	65,085	2,735
150	x	70	10,0	28,705	16	2755,68	36,57	867,196	115,626	4,870	254,937	72,839	2,640
150	x	75	3,0	10,133	20	1215,96	12,91	379,594	50,613	5,423	129,973	34,659	3,173
150	x	75	3,5	11,731	20	1407,72	14,94	434,893	57,986	5,394	148,367	39,565	3,151
150	x	75	4,0	13,304	20	1596,48	16,95	487,997	65,066	5,366	165,883	44,235	3,129
150	x	75	4,5	14,851	20	1782,12	18,92	538,937	71,858	5,337	182,539	48,677	3,106
150	x	75	5,0	16,372	20	1964,64	20,86	587,744	78,366	5,309	198,357	52,895	3,084
150	x	75	6,0	19,337	20	2320,44	24,63	679,075	90,543	5,251	227,555	60,681	3,039
150	x	75	6,3	19,939	20	2392,68	25,40	685,550	91,407	5,195	230,878	61,567	3,015
150	x	75	7,0	21,868	16	2099,33	27,86	738,371	98,450	5,148	247,691	66,051	2,982
150	x	75	8,0	24,525	16	2354,40	31,24	806,273	107,503	5,080	269,009	71,736	2,934
150	x	75	10,0	29,490	12	2123,28	37,57	916,279	122,171	4,939	302,693	80,718	2,839
150	x	80	3,0	10,368	20	1244,16	13,21	395,803	52,774	5,474	150,129	37,532	3,371
150	x	80	3,5	12,006	20	1440,72	15,29	453,676	60,490	5,446	171,542	42,886	3,349
150	x	80	4,0	13,618	20	1634,16	17,35	509,318	67,909	5,418	191,982	47,996	3,327
150	x	80	4,5	15,204	20	1824,48	19,37	562,761	75,035	5,390	211,470	52,867	3,304
150	x	80	5,0	16,765	20	2011,80	21,36	614,036	81,871	5,362	230,025	57,506	3,282

Perfis Ocos Rectangulares

EN 10219 - 3

Dimensões			Espessura (mm)	Massa Linear (Kg/m)	Tubos por Atado	Peso por Atado (Kg)	Secção (cm ²)	Ixx (cm ⁴)	Wxx (cm ³)	ixx (cm)	Iyy (cm ⁴)	Wyy (cm ³)	iyx (cm)
150	x	80	6,0	19,808	20	2376,96	25,23	710,197	94,693	5,305	264,425	66,106	3,237
150	x	80	6,3	20,433	20	2451,96	26,03	718,094	95,746	5,252	268,569	67,142	3,212
150	x	80	8,0	25,153	16	2414,69	32,04	846,644	112,886	5,140	314,126	78,532	3,131
150	x	90	3,0	10,839	24	1560,82	13,81	428,221	57,096	5,569	195,431	43,429	3,762
150	x	90	3,5	12,556	24	1808,06	15,99	491,242	65,499	5,542	223,671	49,705	3,740
150	x	90	4,0	14,246	20	1709,52	18,15	551,961	73,595	5,515	250,737	55,719	3,717
150	x	90	4,5	15,911	20	1909,32	20,27	610,410	81,388	5,488	276,650	61,478	3,694
150	x	90	5,0	17,550	20	2106,00	22,36	666,619	88,883	5,461	301,433	66,985	3,672
150	x	90	6,0	20,750	20	2490,00	26,43	772,441	102,992	5,406	347,701	77,267	3,627
150	x	90	6,3	21,422	20	2570,64	27,29	783,182	104,424	5,357	353,790	78,620	3,601
150	x	90	8,0	26,409	16	2535,26	33,64	927,385	123,651	5,250	416,478	92,551	3,518
150	x	100	3,0	11,310	20	1357,20	14,41	460,639	61,419	5,654	247,637	49,527	4,146
150	x	100	3,5	13,105	20	1572,60	16,69	528,808	70,508	5,628	283,798	56,760	4,123
150	x	100	4,0	14,874	20	1784,88	18,95	594,604	79,280	5,602	318,565	63,713	4,100
150	x	100	4,5	16,617	20	1994,04	21,17	658,058	87,741	5,576	351,964	70,393	4,078
150	x	100	5,0	18,335	20	2200,20	23,36	719,202	95,894	5,549	384,019	76,804	4,055
150	x	100	6,0	21,692	20	2603,04	27,63	834,685	111,291	5,496	444,194	88,839	4,009
150	x	100	6,3	22,411	20	2689,32	28,55	848,271	113,103	5,451	452,657	90,531	3,982
150	x	100	7,0	24,616	16	2363,14	31,36	917,443	122,326	5,409	488,685	97,737	3,948
150	x	100	8,0	27,665	16	2655,84	35,24	1008,127	134,417	5,348	535,651	107,130	3,899
150	x	100	10,0	33,415	12	2405,88	42,57	1161,696	154,893	5,224	614,410	122,882	3,799
150	x	130	3,0	12,723	20	1526,76	16,21	557,893	74,386	5,867	448,680	69,028	5,261
150	x	130	3,5	14,754	20	1770,48	18,79	641,506	85,534	5,842	515,660	79,332	5,238
150	x	130	4,0	16,758	20	2010,96	21,35	722,532	96,338	5,818	580,494	89,307	5,215
150	x	130	4,5	18,737	20	2248,44	23,87	801,003	106,800	5,793	643,212	98,956	5,191
150	x	130	5,0	20,690	20	2482,80	26,36	876,952	116,927	5,768	703,845	108,284	5,168
150	x	130	6,0	24,518	20	2942,16	31,23	1021,417	136,189	5,719	818,972	125,996	5,121
150	x	130	6,3	25,379	12	1827,29	32,33	1043,535	139,138	5,681	837,425	128,835	5,089
150	x	130	7,0	27,913	12	2009,74	35,56	1132,329	150,977	5,643	908,190	139,721	5,054
150	x	130	8,0	31,433	12	2263,18	40,04	1250,351	166,713	5,588	1002,097	154,169	5,003
150	x	130	10,0	38,125	12	2745,00	48,57	1456,196	194,159	5,476	1165,432	179,297	4,899
150	x	130	12,0	43,379	8	2082,19	55,26	1550,666	206,755	5,297	1242,902	191,216	4,743
150	x	130	12,5	44,779	8	2149,39	57,04	1580,459	210,728	5,264	1266,654	194,870	4,712
152	x	76	3,0	10,274	15	924,66	13,09	395,545	52,045	5,497	135,473	35,651	3,217
152	x	76	4,0	13,493	15	1214,37	17,19	508,763	66,942	5,441	173,007	45,528	3,173
152	x	76	4,5	15,063	15	1355,67	19,19	562,018	73,950	5,412	190,438	50,115	3,150
152	x	76	5,0	16,608	15	1494,72	21,16	613,079	80,668	5,383	207,005	54,475	3,128
152	x	76	6,0	19,619	15	1765,71	24,99	708,738	93,255	5,325	237,628	62,534	3,083
152	x	76	6,3	20,235	15	1821,15	25,78	715,946	94,203	5,270	241,228	63,481	3,059

Perfis Ocos Rectangulares

EN 10219 - 3

Dimensões			Espessura (mm)	Massa Linear (Kg/m)	Tubos por Atado	Peso por Atado (Kg)	Secção (cm ²)	Ixx (cm ⁴)	Wxx (cm ³)	Iyy (cm ⁴)	Wyy (cm ³)	Iyy (cm ⁴)	
152	x	76	10,0	29,961	15	2696,49	38,17	959,588	126,262	5,014	317,193	83,472	2,883
160	x	50	3,0	9,426	36	2036,02	12,01	352,880	44,110	5,421	55,965	22,386	2,159
160	x	50	3,5	10,907	36	2355,91	13,89	403,413	50,427	5,388	63,429	25,372	2,137
160	x	50	4,0	12,362	20	1483,44	15,75	451,663	56,458	5,355	70,405	28,162	2,114
160	x	50	4,5	13,791	20	1654,92	17,57	497,662	62,208	5,322	76,908	30,763	2,092
160	x	50	5,0	15,195	20	1823,40	19,36	541,440	67,680	5,289	82,954	33,182	2,070
160	x	50	6,0	17,924	20	2150,88	22,83	622,457	77,807	5,221	93,738	37,495	2,026
160	x	50	6,3	18,455	20	2214,60	23,51	623,114	77,889	5,148	94,530	37,812	2,005
160	x	50	7,0	20,220	20	2426,40	25,76	667,816	83,477	5,092	100,281	40,112	1,973
160	x	50	8,0	22,641	20	2716,92	28,84	723,720	90,465	5,009	107,140	42,856	1,927
160	x	60	3,0	9,897	24	1425,17	12,61	389,858	48,732	5,561	83,915	27,972	2,580
160	x	60	3,5	11,457	20	1374,84	14,59	446,281	55,785	5,530	95,469	31,823	2,558
160	x	60	4,0	12,990	20	1558,80	16,55	500,345	62,543	5,499	106,378	35,459	2,535
160	x	60	4,5	14,498	20	1739,76	18,47	552,082	69,010	5,467	116,658	38,886	2,513
160	x	60	5,0	15,980	20	1917,60	20,36	601,523	75,190	5,436	126,328	42,109	2,491
160	x	60	6,0	18,866	20	2263,92	24,03	693,641	86,705	5,372	143,905	47,968	2,447
160	x	60	6,3	19,444	20	2333,28	24,77	697,570	87,196	5,307	145,665	48,555	2,425
160	x	60	7,0	21,319	20	2558,28	27,16	749,805	93,726	5,254	155,470	51,823	2,393
160	x	60	8,0	23,897	16	2294,11	30,44	816,222	102,028	5,178	167,588	55,863	2,346
160	x	60	10,0	28,705	16	2755,68	36,57	921,003	115,125	5,019	185,678	61,893	2,253
160	x	70	3,0	10,368	20	1244,16	13,21	426,836	53,355	5,685	118,169	33,762	2,991
160	x	70	3,5	12,006	20	1440,72	15,29	489,150	61,144	5,655	134,806	38,516	2,969
160	x	70	4,0	13,618	20	1634,16	17,35	549,028	68,629	5,626	150,624	43,036	2,947
160	x	70	4,5	15,204	20	1824,48	19,37	606,503	75,813	5,596	165,642	47,326	2,924
160	x	70	5,0	16,765	20	2011,80	21,36	661,607	82,701	5,566	179,879	51,394	2,902
160	x	70	6,0	19,808	20	2376,96	25,23	764,825	95,603	5,506	206,089	58,883	2,858
160	x	70	6,3	20,433	20	2451,96	26,03	772,027	96,503	5,446	209,185	59,767	2,835
160	x	70	7,0	22,418	20	2690,16	28,56	831,794	103,974	5,397	224,238	64,068	2,802
160	x	70	8,0	25,153	20	3018,36	32,04	908,723	113,590	5,325	243,257	69,502	2,755
160	x	80	3,0	10,839	24	1560,82	13,81	463,814	57,977	5,796	159,027	39,757	3,394
160	x	80	3,5	12,556	24	1808,06	15,99	532,018	66,502	5,767	181,791	45,448	3,371
160	x	80	4,0	14,246	20	1709,52	18,15	597,711	74,714	5,739	203,545	50,886	3,349
160	x	80	4,5	15,911	20	1909,32	20,27	660,924	82,615	5,710	224,310	56,078	3,327
160	x	80	5,0	17,550	20	2106,00	22,36	721,690	90,211	5,682	244,109	61,027	3,304
160	x	80	6,0	20,750	20	2490,00	26,43	836,009	104,501	5,624	280,889	70,222	3,260
160	x	80	6,3	21,422	20	2570,64	27,29	846,483	105,810	5,569	285,720	71,430	3,236
160	x	80	7,0	23,517	16	2257,63	29,96	913,782	114,223	5,523	307,284	76,821	3,203
160	x	80	8,0	26,409	16	2535,26	33,64	1001,224	125,153	5,455	334,948	83,737	3,155
160	x	80	10,0	31,845	16	3057,12	40,57	1146,336	143,292	5,316	379,811	94,953	3,060

Perfis Ocos Rectangulares

EN 10219 - 3

Dimensões			Espessura (mm)	Massa Linear (Kg/m)	Tubos por Atado	Peso por Atado (Kg)	Secção (cm ²)	Ixx (cm ⁴)	Wxx (cm ³)	ixx (cm)	Iyy (cm ⁴)	Wyy (cm ³)	Iyy (cm)
160	x	90	3,0	11,310	20	1357,20	14,41	500,792	62,599	5,896	206,789	45,953	3,788
160	x	90	3,5	13,105	20	1572,60	16,69	574,887	71,861	5,868	236,772	52,616	3,766
160	x	90	4,0	14,874	20	1784,88	18,95	646,393	80,799	5,841	265,539	59,009	3,744
160	x	90	4,5	16,617	20	1994,04	21,17	715,345	89,418	5,813	293,113	65,136	3,721
160	x	90	5,0	18,335	20	2200,20	23,36	781,773	97,722	5,785	319,516	71,004	3,699
160	x	90	6,0	21,692	20	2603,04	27,63	907,193	113,399	5,730	368,905	81,979	3,654
160	x	90	6,3	22,411	20	2689,32	28,55	920,939	115,117	5,680	375,900	83,533	3,629
160	x	90	7,0	24,616	16	2363,14	31,36	995,771	124,471	5,635	405,309	90,069	3,595
160	x	90	8,0	27,665	16	2655,84	35,24	1093,726	136,716	5,571	443,459	98,547	3,547
160	x	90	10,0	33,415	12	2405,88	42,57	1259,003	157,375	5,439	506,802	112,623	3,451
160	x	100	3,0	11,781	20	1413,72	15,01	537,770	67,221	5,986	261,755	52,351	4,176
160	x	100	3,5	13,655	20	1638,60	17,39	617,755	77,219	5,959	300,101	60,020	4,154
160	x	100	4,0	15,502	20	1860,24	19,75	695,076	86,885	5,933	337,008	67,402	4,131
160	x	100	4,5	17,324	20	2078,88	22,07	769,765	96,221	5,906	372,500	74,500	4,108
160	x	100	5,0	19,120	18	2064,96	24,36	841,857	105,232	5,879	406,602	81,320	4,086
160	x	100	6,0	22,634	18	2444,47	28,83	978,377	122,297	5,825	470,738	94,148	4,041
160	x	100	6,3	23,401	18	2527,31	29,81	995,395	124,424	5,779	480,355	96,071	4,014
160	x	100	7,0	25,715	16	2468,64	32,76	1077,760	134,720	5,736	519,013	103,803	3,980
160	x	100	8,0	28,921	16	2776,42	36,84	1186,227	148,278	5,674	569,592	113,918	3,932
160	x	100	10,0	34,985	12	2518,92	44,57	1371,670	171,459	5,548	655,077	131,015	3,834
160	x	100	12,0	39,611	9	2138,99	50,46	1434,089	179,261	5,331	688,574	137,715	3,694
160	x	120	3,0	12,723	20	1526,76	16,21	611,726	76,466	6,143	394,499	65,750	4,934
160	x	120	3,5	14,754	20	1770,48	18,79	703,493	87,937	6,118	453,201	75,533	4,911
160	x	120	4,0	16,758	20	2010,96	21,35	792,441	99,055	6,093	509,967	84,994	4,888
160	x	120	4,5	18,737	20	2248,44	23,87	878,607	109,826	6,067	564,826	94,138	4,865
160	x	120	5,0	20,690	20	2482,80	26,36	962,023	120,253	6,042	617,808	102,968	4,842
160	x	120	6,0	24,518	16	2353,73	31,23	1120,745	140,093	5,990	718,253	119,709	4,795
160	x	120	6,3	25,379	16	2436,38	32,33	1144,308	143,039	5,949	734,608	122,435	4,767
160	x	120	7,0	27,913	12	2009,74	35,56	1241,737	155,217	5,909	796,258	132,710	4,732
160	x	120	8,0	31,433	12	2263,18	40,04	1371,230	171,404	5,852	877,921	146,320	4,682
160	x	120	10,0	38,125	9	2058,75	48,57	1597,003	199,625	5,734	1019,475	169,912	4,582
160	x	120	12,0	43,379	9	2342,47	55,26	1697,513	212,189	5,542	1086,784	181,131	4,435
160	x	120	12,5	44,779	9	2418,07	57,04	1729,831	216,229	5,507	1107,222	184,537	4,406
160	x	140	3,0	13,665	16	1311,84	17,41	685,682	85,710	6,276	559,661	79,952	5,670
160	x	140	3,5	15,853	16	1521,89	20,19	789,230	98,654	6,252	643,889	91,984	5,647
160	x	140	4,0	18,014	16	1729,34	22,95	889,807	111,226	6,227	725,621	103,660	5,623
160	x	140	4,5	20,150	16	1934,40	25,67	987,448	123,431	6,202	804,889	114,984	5,600
160	x	140	5,0	22,260	16	2136,96	28,36	1082,190	135,274	6,178	881,726	125,961	5,576
160	x	140	6,0	26,402	16	2534,59	33,63	1263,113	157,889	6,128	1028,234	146,891	5,529

Perfis Ocos Rectangulares

EN 10219 - 3

Dimensões			Espessura (mm)	Massa Linear (Kg/m)	Tubos por Atado	Peso por Atado (Kg)	Secção (cm ²)	Ixx (cm ⁴)	Wxx (cm ³)	Iyy (cm ⁴)	Wyy (cm ³)	Iyy (cm ⁴)	
160	x	140	6,3	27,357	16	2626,27	34,85	1293,221	161,653	6,092	1053,521	150,503	5,498
160	x	140	7,0	30,111	12	2167,99	38,36	1405,714	175,714	6,054	1144,617	163,517	5,463
160	x	140	8,0	33,945	12	2444,04	43,24	1556,232	194,529	5,999	1266,336	180,905	5,412
160	x	140	10,0	41,265	9	2228,31	52,57	1822,336	227,792	5,888	1481,006	211,572	5,308
160	x	140	12,0	47,147	9	2545,94	60,06	1960,937	245,117	5,714	1595,513	227,930	5,154
160	x	140	12,5	48,704	9	2630,02	62,04	2002,436	250,304	5,681	1629,087	232,727	5,124
180	x	60	3,0	10,839	24	1560,82	13,81	526,852	58,539	6,177	93,671	31,224	2,605
180	x	60	3,5	12,556	20	1506,72	15,99	603,998	67,111	6,145	106,656	35,552	2,582
180	x	60	4,0	14,246	20	1709,52	18,15	678,192	75,355	6,113	118,943	39,648	2,560
180	x	60	4,5	15,911	20	1909,32	20,27	749,470	83,274	6,081	130,550	43,517	2,538
180	x	60	5,0	17,550	20	2106,00	22,36	817,866	90,874	6,048	141,494	47,165	2,516
180	x	60	6,0	20,750	20	2490,00	26,43	946,154	105,128	5,983	161,473	53,824	2,472
180	x	60	6,3	21,422	20	2570,64	27,29	954,659	106,073	5,915	163,916	54,639	2,451
180	x	60	7,0	23,517	20	2822,04	29,96	1028,995	114,333	5,861	175,247	58,416	2,419
180	x	60	8,0	26,409	20	3169,08	33,64	1124,806	124,978	5,782	189,391	63,130	2,373
180	x	60	10,0	31,845	15	2866,05	40,57	1280,799	142,311	5,619	211,012	70,337	2,281
180	x	70	3,0	11,310	20	1357,20	14,41	573,850	63,761	6,311	131,645	37,613	3,023
180	x	70	3,5	13,105	20	1572,60	16,69	658,521	73,169	6,281	150,299	42,942	3,000
180	x	70	4,0	14,874	20	1784,88	18,95	740,155	82,239	6,250	168,070	48,020	2,978
180	x	70	4,5	16,617	20	1994,04	21,17	818,786	90,976	6,219	184,979	52,851	2,956
180	x	70	5,0	18,335	20	2200,20	23,36	894,449	99,383	6,188	201,046	57,442	2,934
180	x	70	6,0	21,692	20	2603,04	27,63	1037,018	115,224	6,126	230,737	65,925	2,890
180	x	70	6,3	22,411	20	2689,32	28,55	1049,742	116,638	6,064	234,832	67,095	2,868
180	x	70	7,0	24,616	18	2658,53	31,36	1133,803	125,978	6,013	252,135	72,039	2,836
180	x	70	8,0	27,665	18	2987,82	35,24	1243,227	138,136	5,939	274,180	78,337	2,789
180	x	70	10,0	33,415	12	2405,88	42,57	1425,466	158,385	5,787	309,437	88,410	2,696
180	x	80	3,0	11,781	20	1413,72	15,01	620,848	68,983	6,432	176,823	44,206	3,432
180	x	80	3,5	13,655	20	1638,60	17,39	713,045	79,227	6,403	202,288	50,572	3,410
180	x	80	4,0	15,502	20	1860,24	19,75	802,117	89,124	6,373	226,670	56,668	3,388
180	x	80	4,5	17,324	20	2078,88	22,07	888,101	98,678	6,344	249,992	62,498	3,366
180	x	80	5,0	19,120	20	2294,40	24,36	971,033	107,893	6,314	272,275	68,069	3,343
180	x	80	6,0	22,634	20	2716,08	28,83	1127,882	125,320	6,254	313,817	78,454	3,299
180	x	80	6,3	23,401	20	2808,12	29,81	1144,824	127,203	6,197	320,023	80,006	3,277
180	x	80	7,0	25,715	16	2468,64	32,76	1238,612	137,624	6,149	344,701	86,175	3,244
180	x	80	8,0	28,921	16	2776,42	36,84	1361,648	151,294	6,079	376,590	94,148	3,197
180	x	80	10,0	34,985	12	2518,92	44,57	1570,133	174,459	5,936	429,145	107,286	3,103
180	x	80	12,0	39,611	8	1901,33	50,46	1625,872	180,652	5,676	447,347	111,837	2,977
180	x	80	12,5	40,854	8	1960,99	52,04	1649,663	183,296	5,630	453,357	113,339	2,951
180	x	100	3,0	12,723	20	1526,76	16,21	714,844	79,427	6,641	289,991	57,998	4,230

Perfis Ocos Rectangulares

EN 10219 - 3

Dimensões			Espessura (mm)	Massa Linear (Kg/m)	Tubos por Atado	Peso por Atado (Kg)	Secção (cm ²)	Ixx (cm ⁴)	Wxx (cm ³)	ixx (cm)	Iyy (cm ⁴)	Wyy (cm ³)	iyy (cm)
180	x	100	3,5	14,754	20	1770,48	18,79	822,092	91,344	6,614	332,708	66,542	4,207
180	x	100	4,0	16,758	20	2010,96	21,35	926,043	102,894	6,586	373,893	74,779	4,185
180	x	100	4,5	18,737	20	2248,44	23,87	1026,733	114,081	6,559	413,571	82,714	4,163
180	x	100	5,0	20,690	20	2482,80	26,36	1124,199	124,911	6,531	451,769	90,354	4,140
180	x	100	6,0	24,518	16	2353,73	31,23	1309,610	145,512	6,475	523,826	104,765	4,095
180	x	100	6,3	25,379	16	2436,38	32,33	1334,989	148,332	6,426	535,750	107,150	4,071
180	x	100	7,0	27,913	12	2009,74	35,56	1448,229	160,914	6,382	579,671	115,934	4,038
180	x	100	8,0	31,433	12	2263,18	40,04	1598,491	177,610	6,318	637,475	127,495	3,990
180	x	100	10,0	38,125	12	2745,00	48,57	1859,466	206,607	6,188	736,410	147,282	3,894
180	x	100	12,0	43,379	4	1041,10	55,26	1965,136	218,348	5,963	782,078	156,416	3,762
180	x	100	12,5	44,779	4	1074,70	57,04	2001,017	222,335	5,923	795,798	159,160	3,735
180	x	120	3,0	13,665	20	1639,80	17,41	808,840	89,871	6,816	435,575	72,596	5,002
180	x	120	3,5	15,853	20	1902,36	20,19	931,139	103,460	6,790	500,718	83,453	4,979
180	x	120	4,0	18,014	20	2161,68	22,95	1049,968	116,663	6,764	563,812	93,969	4,957
180	x	120	4,5	20,150	20	2418,00	25,67	1165,364	129,485	6,738	624,887	104,148	4,934
180	x	120	5,0	22,260	20	2671,20	28,36	1277,366	141,930	6,712	683,975	113,996	4,911
180	x	120	6,0	26,402	16	2534,59	33,63	1491,338	165,704	6,659	796,301	132,717	4,866
180	x	120	6,3	27,357	16	2626,27	34,85	1525,154	169,462	6,615	816,136	136,023	4,839
180	x	120	7,0	30,111	12	2167,99	38,36	1657,847	184,205	6,574	885,755	147,626	4,805
180	x	120	8,0	33,945	12	2444,04	43,24	1835,334	203,926	6,515	978,444	163,074	4,757
180	x	120	10,0	41,265	9	2228,31	52,57	2148,799	238,755	6,394	1140,808	190,135	4,659
180	x	120	12,0	47,147	9	2545,94	60,06	2304,400	256,044	6,194	1227,328	204,555	4,521
180	x	120	12,5	48,704	9	2630,02	62,04	2352,371	261,375	6,157	1252,326	208,721	4,493
180	x	140	3,0	14,607	16	1402,27	18,61	902,836	100,315	6,965	615,977	87,997	5,753
180	x	140	3,5	16,952	16	1627,39	21,59	1040,187	115,576	6,940	709,116	101,302	5,730
180	x	140	4,0	19,270	16	1849,92	24,55	1173,893	130,433	6,915	799,627	114,232	5,707
180	x	140	4,5	21,563	16	2070,05	27,47	1303,996	144,888	6,890	887,541	126,792	5,684
180	x	140	5,0	23,830	16	2287,68	30,36	1430,533	158,948	6,865	972,893	138,985	5,661
180	x	140	6,0	28,286	16	2715,46	36,03	1673,066	185,896	6,814	1136,042	162,292	5,615
180	x	140	6,3	29,335	16	2816,16	37,37	1715,319	190,591	6,775	1166,221	166,603	5,586
180	x	140	7,0	32,309	12	2326,25	41,16	1867,464	207,496	6,736	1268,555	181,222	5,552
180	x	140	8,0	36,457	12	2624,90	46,44	2072,176	230,242	6,680	1405,898	200,843	5,502
180	x	140	10,0	44,405	8	2131,44	56,57	2438,133	270,904	6,565	1650,339	235,763	5,401
180	x	140	12,0	50,915	8	2443,92	64,86	2643,664	293,740	6,384	1792,697	256,100	5,257
180	x	140	12,5	52,629	8	2526,19	67,04	2703,726	300,414	6,350	1832,941	261,849	5,229
200	x	70	3,0	12,252	21	1543,75	15,61	749,681	74,968	6,930	145,121	41,463	3,049
200	x	70	3,5	14,204	21	1789,70	18,09	861,282	86,128	6,899	165,791	47,369	3,027
200	x	70	4,0	16,130	21	2032,38	20,55	969,177	96,918	6,868	185,515	53,004	3,005
200	x	70	4,5	18,030	21	2271,78	22,97	1073,405	107,341	6,836	204,315	58,376	2,983

Perfis Ocos Rectangulares

EN 10219 - 3

Dimensões			Espessura (mm)	Massa Linear (Kg/m)	Tubos por Atado	Peso por Atado (Kg)	Secção (cm²)	Ixx (cm⁴)	Wxx (cm³)	ixx (cm)	Iyy (cm⁴)	Wyy (cm³)	Iyy (cm)
200	x	70	5,0	19,905	21	2508,03	25,36	1174,005	117,400	6,804	222,213	63,489	2,960
200	x	70	6,0	23,576	16	2263,30	30,03	1364,476	136,448	6,740	255,385	72,967	2,916
200	x	70	6,3	24,390	16	2341,44	31,07	1384,557	138,456	6,676	260,479	74,423	2,895
200	x	70	7,0	26,814	16	2574,14	34,16	1498,528	149,853	6,624	280,032	80,009	2,863
200	x	70	8,0	30,177	16	2896,99	38,44	1648,216	164,822	6,548	305,103	87,172	2,817
200	x	80	3,0	12,723	21	1603,10	16,21	807,899	80,790	7,060	194,619	48,655	3,465
200	x	80	3,5	14,754	21	1859,00	18,79	928,861	92,886	7,030	222,785	55,696	3,443
200	x	80	4,0	16,758	21	2111,51	21,35	1046,020	104,602	7,000	249,795	62,449	3,421
200	x	80	4,5	18,737	21	2360,86	23,87	1159,416	115,942	6,970	275,673	68,918	3,398
200	x	80	5,0	20,690	21	2606,94	26,36	1269,088	126,909	6,939	300,442	75,111	3,376
200	x	80	6,0	24,518	15	2206,62	31,23	1477,420	147,742	6,878	346,745	86,686	3,332
200	x	80	6,3	25,379	15	2284,11	32,33	1502,785	150,279	6,818	354,326	88,582	3,311
200	x	80	7,0	27,913	12	2009,74	35,56	1628,957	162,896	6,768	382,119	95,530	3,278
200	x	80	8,0	31,433	12	2263,18	40,04	1795,758	179,576	6,697	418,233	104,558	3,232
200	x	80	10,0	38,125	9	2058,75	48,57	2083,062	208,306	6,549	478,478	119,619	3,139
200	x	80	12,0	43,379	9	2342,47	55,26	2181,997	218,200	6,284	503,411	125,853	3,018
200	x	80	12,5	44,779	9	2418,07	57,04	2218,791	221,879	6,237	510,962	127,740	2,993
200	x	100	3,5	15,853	18	1712,12	20,19	1064,018	106,402	7,259	365,315	73,063	4,253
200	x	100	4,0	18,014	18	1945,51	22,95	1199,705	119,971	7,230	410,778	82,156	4,231
200	x	100	4,0	18,014	18	1945,51	22,95	1199,705	119,971	7,230	410,778	82,156	4,231
200	x	100	4,5	20,150	18	2176,20	25,67	1331,437	133,144	7,202	454,643	90,929	4,209
200	x	100	5,0	22,260	18	2404,08	28,36	1459,255	145,925	7,174	496,935	99,387	4,186
200	x	100	6,0	26,402	15	2376,18	33,63	1703,308	170,331	7,116	576,914	115,383	4,142
200	x	100	6,3	27,357	15	2462,13	34,85	1739,243	173,924	7,064	591,145	118,229	4,119
200	x	100	7,0	30,111	12	2167,99	38,36	1889,814	188,981	7,019	640,328	128,066	4,086
200	x	100	8,0	33,945	12	2444,04	43,24	2090,840	209,084	6,954	705,357	141,071	4,039
200	x	100	10,0	41,265	9	2228,31	52,57	2444,395	244,440	6,819	817,743	163,549	3,944
200	x	100	12,0	47,147	9	2545,94	60,06	2606,701	260,670	6,588	875,582	175,116	3,818
200	x	100	12,5	48,704	9	2630,02	62,04	2658,895	265,889	6,546	892,152	178,430	3,792
200	x	120	3,0	14,607	16	1402,27	18,61	1040,771	104,077	7,479	476,651	79,442	5,061
200	x	120	3,5	16,952	16	1627,39	21,59	1199,175	119,918	7,452	548,235	91,373	5,039
200	x	120	4,0	19,270	16	1849,92	24,55	1353,391	135,339	7,425	617,657	102,943	5,016
200	x	120	4,5	21,563	16	2070,05	27,47	1503,459	150,346	7,398	684,949	114,158	4,994
200	x	120	5,0	23,830	16	2287,68	30,36	1649,421	164,942	7,371	750,141	125,024	4,971
200	x	120	6,0	28,286	16	2715,46	36,03	1929,196	192,920	7,317	874,349	145,725	4,926
200	x	120	6,3	29,335	16	2816,16	37,37	1975,700	197,570	7,271	897,664	149,611	4,901
200	x	120	7,0	32,309	12	2326,25	41,16	2150,671	215,067	7,229	975,253	162,542	4,868
200	x	120	8,0	36,457	12	2624,90	46,44	2385,923	238,592	7,168	1078,967	179,828	4,820
200	x	120	10,0	44,405	9	2397,87	56,57	2805,729	280,573	7,043	1262,142	210,357	4,724

Perfis Ocos Rectangulares

EN 10219 - 3

Dimensões		Espessura (mm)		Massa Linear (Kg/m)	Tubos por Atado	Peso por Atado (Kg)	Secção (cm ²)	Ixx (cm ⁴)	Wxx (cm ³)	ixx (cm)	Iyy (cm ⁴)	Wyy (cm ³)	Iyy (cm)
200	x	120	12,0	50,915	9	2749,41	64,86	3031,405	303,141	6,837	1367,872	227,979	4,592
200	x	120	12,5	52,629	9	2841,97	67,04	3098,999	309,900	6,799	1397,430	232,905	4,565
200	x	150	3,0	16,020	12	1153,44	20,41	1215,425	121,542	7,717	784,819	104,643	6,201
200	x	150	3,5	18,600	12	1339,20	23,69	1401,911	140,191	7,692	904,469	120,596	6,178
200	x	150	4,0	21,154	12	1523,09	26,95	1583,919	158,392	7,667	1021,030	136,137	6,155
200	x	150	4,5	23,682	12	1705,10	30,17	1761,491	176,149	7,641	1134,540	151,272	6,132
200	x	150	5,0	26,185	12	1885,32	33,36	1934,671	193,467	7,616	1245,036	166,005	6,109
200	x	150	6,0	31,112	12	2240,06	39,63	2268,028	226,803	7,565	1457,125	194,283	6,063
200	x	150	6,3	32,302	12	2325,74	41,15	2330,386	233,039	7,525	1499,153	199,887	6,036
200	x	150	7,0	35,606	9	1922,72	45,36	2541,957	254,196	7,486	1633,730	217,831	6,002
200	x	150	8,0	40,225	9	2172,15	51,24	2828,547	282,855	7,430	1815,540	242,072	5,952
200	x	150	10,0	49,115	9	2652,21	62,57	3347,729	334,773	7,315	2143,363	285,782	5,853
200	x	150	12,0	56,567	6	2036,41	72,06	3668,461	366,846	7,135	2352,530	313,671	5,714
200	x	150	12,5	58,517	6	2106,61	74,54	3759,155	375,916	7,101	2409,886	321,318	5,686
200	x	160	3,0	16,491	12	1187,35	21,01	1273,643	127,364	7,786	907,550	113,444	6,573
200	x	160	3,5	19,150	12	1378,80	24,39	1469,490	146,949	7,761	1046,441	130,805	6,550
200	x	160	4,0	21,782	12	1568,30	27,75	1660,761	166,076	7,736	1181,903	147,738	6,526
200	x	160	4,5	24,389	12	1756,01	31,07	1847,502	184,750	7,711	1313,973	164,247	6,503
200	x	160	5,0	26,970	12	1941,84	34,36	2029,755	202,975	7,686	1442,690	180,336	6,480
200	x	160	6,0	32,054	12	2307,89	40,83	2380,972	238,097	7,636	1690,217	211,277	6,434
200	x	160	6,3	33,292	12	2397,02	42,41	2448,615	244,861	7,599	1739,958	217,495	6,405
200	x	160	7,0	36,705	9	1982,07	46,76	2672,386	267,239	7,560	1897,646	237,206	6,371
200	x	160	8,0	41,481	9	2239,97	52,84	2976,088	297,609	7,505	2111,240	263,905	6,321
200	x	160	10,0	50,685	9	2736,99	64,57	3528,395	352,840	7,392	2498,336	312,292	6,220
200	x	160	12,0	58,451	6	2104,24	74,46	3880,813	388,081	7,219	2751,209	343,901	6,079
200	x	160	12,5	60,479	6	2177,24	77,04	3979,207	397,921	7,187	2820,248	352,531	6,050
220	x	80	3,0	13,665	18	1475,82	17,41	1027,366	93,397	7,682	212,415	53,104	3,493
220	x	80	3,5	15,853	18	1712,12	20,19	1182,266	107,479	7,651	243,282	60,821	3,471
220	x	80	4,0	18,014	18	1945,51	22,95	1332,618	121,147	7,620	272,921	68,230	3,449
220	x	80	4,5	20,150	18	2176,20	25,67	1478,467	134,406	7,589	301,355	75,339	3,426
220	x	80	5,0	22,260	18	2404,08	28,36	1619,856	147,260	7,558	328,609	82,152	3,404
220	x	80	6,0	26,402	18	2851,42	33,63	1889,424	171,766	7,495	379,673	94,918	3,360
220	x	80	6,3	27,357	18	2954,56	34,85	1925,405	175,037	7,433	388,629	97,157	3,339
220	x	80	7,0	30,111	9	1625,99	38,36	2090,416	190,038	7,382	419,536	104,884	3,307
220	x	80	8,0	33,945	9	1833,03	43,24	2309,952	209,996	7,309	459,876	114,969	3,261
220	x	80	10,0	41,265	9	2228,31	52,57	2693,124	244,829	7,158	527,811	131,953	3,169
220	x	80	12,0	47,147	9	2545,94	60,06	2848,642	258,967	6,887	559,475	139,869	3,052
220	x	80	12,5	48,704	9	2630,02	62,04	2902,005	263,819	6,839	568,566	142,141	3,027
220	x	100	3,0	14,607	15	1314,63	18,61	1168,642	106,240	7,925	346,463	69,293	4,315

Perfis Ocos Rectangulares

EN 10219 - 3

Dimensões			Espessura (mm)	Massa Linear (Kg/m)	Tubos por Atado	Peso por Atado (Kg)	Secção (cm ²)	Ixx (cm ⁴)	Wxx (cm ³)	ixx (cm)	Iyy (cm ⁴)	Wyy (cm ³)	Iyy (cm)
220	x	100	3,5	16,952	15	1525,68	21,59	1346,333	122,394	7,896	397,923	79,585	4,293
220	x	100	4,0	19,270	15	1734,30	24,55	1519,264	138,115	7,867	447,664	89,533	4,270
220	x	100	4,5	21,563	15	1940,67	27,47	1687,479	153,407	7,838	495,714	99,143	4,248
220	x	100	5,0	23,830	15	2144,70	30,36	1851,022	168,275	7,809	542,102	108,420	4,226
220	x	100	6,0	28,286	15	2545,74	36,03	2164,272	196,752	7,750	630,002	126,000	4,181
220	x	100	6,3	29,335	15	2640,15	37,37	2213,195	201,200	7,696	646,541	129,308	4,159
220	x	100	7,0	32,309	9	1744,69	41,16	2408,114	218,919	7,649	700,985	140,197	4,127
220	x	100	8,0	36,457	9	1968,68	46,44	2669,674	242,698	7,582	773,240	154,648	4,080
220	x	100	10,0	44,405	9	2397,87	56,57	3134,457	284,951	7,444	899,077	179,815	3,987
220	x	100	12,0	50,915	9	2749,41	64,86	3368,386	306,217	7,206	969,086	193,817	3,865
220	x	100	12,5	52,629	9	2841,97	67,04	3440,860	312,805	7,164	988,506	197,701	3,840
220	x	120	3,0	15,549	12	1119,53	19,81	1309,918	119,083	8,132	517,727	86,288	5,112
220	x	120	3,5	18,051	12	1299,67	22,99	1510,400	137,309	8,105	595,752	99,292	5,090
220	x	120	4,0	20,526	12	1477,87	26,15	1705,909	155,083	8,077	671,503	111,917	5,068
220	x	120	4,5	22,976	12	1654,27	29,27	1896,490	172,408	8,050	745,010	124,168	5,045
220	x	120	5,0	25,400	12	1828,80	32,36	2082,189	189,290	8,022	816,308	136,051	5,023
220	x	120	6,0	30,170	12	2172,24	38,43	2439,120	221,738	7,966	952,397	158,733	4,978
220	x	120	6,3	31,313	12	2254,54	39,89	2500,985	227,362	7,918	979,192	163,199	4,955
220	x	120	7,0	34,507	9	1863,38	43,96	2725,811	247,801	7,875	1064,750	177,458	4,922
220	x	120	8,0	38,969	9	2104,33	49,64	3029,397	275,400	7,812	1179,489	196,582	4,874
220	x	120	10,0	47,545	9	2567,43	60,57	3575,790	325,072	7,684	1383,475	230,579	4,779
220	x	120	12,0	54,683	8	2624,78	69,66	3888,130	353,466	7,471	1508,416	251,403	4,653
220	x	120	12,5	56,554	8	2714,59	72,04	3979,714	361,792	7,432	1542,534	257,089	4,627
220	x	130	3,0	16,020	12	1153,44	20,41	1380,556	125,505	8,225	618,066	95,087	5,503
220	x	130	3,5	18,600	12	1339,20	23,69	1592,434	144,767	8,198	711,738	109,498	5,481
220	x	130	4,0	21,154	12	1523,09	26,95	1799,232	163,567	8,171	802,833	123,513	5,458
220	x	130	4,5	23,682	12	1705,10	30,17	2000,996	181,909	8,144	891,385	137,136	5,436
220	x	130	5,0	26,185	12	1885,32	33,36	2197,772	199,797	8,117	977,428	150,374	5,413
220	x	130	6,0	31,112	12	2240,06	39,63	2576,544	234,231	8,063	1142,120	175,711	5,368
220	x	130	6,3	32,302	12	2325,74	41,15	2644,880	240,444	8,017	1175,119	180,788	5,344
220	x	130	7,0	35,606	9	1922,72	45,36	2884,660	262,242	7,975	1279,250	196,808	5,311
220	x	130	8,0	40,225	9	2172,15	51,24	3209,258	291,751	7,914	1419,446	218,376	5,263
220	x	130	10,0	49,115	9	2652,21	62,57	3796,457	345,132	7,790	1670,599	257,015	5,167
220	x	130	12,0	56,567	6	2036,41	72,06	4148,002	377,091	7,587	1829,726	281,496	5,039
220	x	130	12,5	58,517	6	2106,61	74,54	4249,141	386,286	7,550	1872,956	288,147	5,013
220	x	140	3,0	16,491	15	1484,19	21,01	1451,194	131,927	8,311	728,609	104,087	5,889
220	x	140	3,5	19,150	15	1723,50	24,39	1674,467	152,224	8,285	839,571	119,939	5,867
220	x	140	4,0	21,782	15	1960,38	27,75	1892,554	172,050	8,259	947,637	135,377	5,844
220	x	140	4,5	24,389	15	2195,01	31,07	2105,502	191,409	8,232	1052,844	150,406	5,821

Perfis Ocos Rectangulares

EN 10219 - 3

Dimensões			Espessura (mm)	Massa Linear (Kg/m)	Tubos por Atado	Peso por Atado (Kg)	Secção (cm ²)	Ixx (cm ⁴)	Wxx (cm ³)	ixx (cm)	Iyy (cm ⁴)	Wyy (cm ³)	Iyy (cm)
220	x	140	5,0	26,970	15	2427,30	34,36	2313,356	210,305	8,206	1155,226	165,032	5,799
220	x	140	6,0	32,054	12	2307,89	40,83	2713,968	246,724	8,153	1351,658	193,094	5,753
220	x	140	6,3	33,292	12	2397,02	42,41	2788,775	253,525	8,109	1391,622	198,803	5,728
220	x	140	7,0	36,705	9	1982,07	46,76	3043,508	276,683	8,068	1516,429	216,633	5,695
220	x	140	8,0	41,481	9	2239,97	52,84	3389,120	308,102	8,009	1685,024	240,718	5,647
220	x	140	10,0	50,685	9	2736,99	64,57	4017,124	365,193	7,888	1989,006	284,144	5,550
220	x	140	12,0	58,451	6	2104,24	74,46	4407,874	400,716	7,694	2187,065	312,438	5,420
220	x	140	12,5	60,479	6	2177,24	77,04	4518,568	410,779	7,658	2240,650	320,093	5,393
220	x	180	4,0	24,294	12	1749,17	30,95	2265,845	205,986	8,557	1669,595	185,511	7,345
220	x	180	4,5	27,215	12	1959,48	34,67	2523,525	229,411	8,532	1858,522	206,502	7,322
220	x	180	5,0	30,110	12	2167,92	38,36	2775,689	252,335	8,507	2043,199	227,022	7,299
220	x	180	6,0	35,822	12	2579,18	45,63	3263,664	296,697	8,457	2399,978	266,664	7,252
220	x	180	6,3	37,248	12	2681,86	47,45	3364,354	305,850	8,420	2475,979	275,109	7,224
220	x	180	7,0	41,101	9	2219,45	52,36	3678,903	334,446	8,382	2705,933	300,659	7,189
220	x	180	8,0	46,505	9	2511,27	59,24	4108,565	373,506	8,328	3019,547	335,505	7,139
220	x	180	10,0	56,965	9	3076,11	72,57	4899,790	445,435	8,217	3595,466	399,496	7,039
220	x	180	12,0	65,987	6	2375,53	84,06	5447,362	495,215	8,050	4000,720	444,524	6,899
220	x	180	12,5	68,329	6	2459,84	87,04	5596,276	508,752	8,018	4109,142	456,571	6,871
250	x	50	3,0	13,665	20	1639,80	17,41	1148,043	91,843	8,121	85,827	34,331	2,220
250	x	50	3,5	15,853	20	1902,36	20,19	1319,954	105,596	8,085	97,549	39,020	2,198
250	x	50	4,0	18,014	20	2161,68	22,95	1486,443	118,915	8,048	108,589	43,436	2,175
250	x	50	4,5	20,150	20	2418,00	25,67	1647,557	131,805	8,012	118,967	47,587	2,153
250	x	50	5,0	22,260	18	2404,08	28,36	1803,343	144,267	7,975	128,704	51,482	2,130
250	x	50	6,0	26,402	16	2534,59	33,63	2099,122	167,930	7,900	146,334	58,534	2,086
250	x	50	6,3	27,357	16	2626,27	34,85	2130,239	170,419	7,818	149,044	59,618	2,068
250	x	50	7,0	30,111	12	2167,99	38,36	2308,010	184,641	7,757	159,039	63,615	2,036
250	x	50	8,0	33,945	12	2444,04	43,24	2542,378	203,390	7,668	171,412	68,565	1,991
250	x	50	10,0	41,265	12	2971,08	52,57	2943,341	235,467	7,483	190,037	76,015	1,901
250	x	100	3,0	16,020	12	1153,44	20,41	1605,633	128,451	8,870	388,817	77,763	4,365
250	x	100	3,5	18,600	12	1339,20	23,69	1851,660	148,133	8,840	446,833	89,367	4,343
250	x	100	4,0	21,154	12	1523,09	26,95	2091,656	167,333	8,810	502,992	100,598	4,320
250	x	100	4,5	23,682	12	1705,10	30,17	2325,673	186,054	8,780	557,321	111,464	4,298
250	x	100	5,0	26,185	12	1885,32	33,36	2553,760	204,301	8,750	609,852	121,970	4,276
250	x	100	6,0	31,112	12	2240,06	39,63	2992,342	239,387	8,689	709,634	141,927	4,231
250	x	100	6,3	32,302	12	2325,74	41,15	3065,835	245,267	8,632	729,634	145,927	4,211
250	x	100	7,0	35,606	9	1922,72	45,36	3341,654	267,332	8,583	791,971	158,394	4,179
250	x	100	8,0	40,225	9	2172,15	51,24	3714,085	297,127	8,514	875,064	175,013	4,132
250	x	100	10,0	49,115	9	2652,21	62,57	4384,174	350,734	8,371	1021,077	204,215	4,040
250	x	100	12,0	56,567	6	2036,41	72,06	4757,136	380,571	8,125	1109,342	221,868	3,924

Perfis Ocos Rectangulares

EN 10219 - 3

Dimensões		Espe- sura (mm)	Massa Linear (Kg/m)	Tubos por Atado	Peso por Atado (Kg)	Secção (cm ²)	Ixx (cm ⁴)	Wxx (cm ³)	ixx (cm)	Iyy (cm ⁴)	Wyy (cm ³)	Iyy (cm)	
250	x	100	12,5	58,517	6	2106,61	74,54	4868,346	389,468	8,081	1133,038	226,608	3,899
250	x	150	4,0	24,294	12	1749,17	30,95	2696,870	215,750	9,335	1234,244	164,566	6,315
250	x	150	4,5	27,215	12	1959,48	34,67	3003,789	240,303	9,308	1372,782	183,038	6,293
250	x	150	5,0	30,110	12	2167,92	38,36	3304,176	264,334	9,281	1507,952	201,060	6,270
250	x	150	6,0	35,822	12	2579,18	45,63	3885,562	310,845	9,228	1768,345	235,779	6,225
250	x	150	6,3	37,248	12	2681,86	47,45	4001,430	320,114	9,183	1824,594	243,279	6,201
250	x	150	7,0	41,101	9	2219,45	52,36	4375,297	350,024	9,141	1991,873	265,583	6,168
250	x	150	8,0	46,505	9	2511,27	59,24	4885,792	390,863	9,081	2219,247	295,900	6,120
250	x	150	10,0	56,965	9	3076,11	72,57	5825,007	466,001	8,959	2634,196	351,226	6,025
250	x	150	12,0	65,987	6	2375,53	84,06	6457,896	516,632	8,765	2925,290	390,039	5,899
250	x	150	12,5	68,329	6	2459,84	87,04	6632,669	530,613	8,729	3002,334	400,311	5,873
250	x	200	4,0	27,434	6	987,62	34,95	3302,083	264,167	9,720	2352,345	235,235	8,204
250	x	200	4,5	30,747	6	1106,89	39,17	3681,906	294,552	9,695	2621,599	262,160	8,181
250	x	200	5,0	34,035	6	1225,26	43,36	4054,593	324,367	9,670	2885,505	288,550	8,158
250	x	200	6,0	40,532	6	1459,15	51,63	4778,782	382,303	9,620	3397,468	339,747	8,112
250	x	200	6,3	42,193	6	1518,95	53,75	4937,026	394,962	9,584	3512,673	351,267	8,084
250	x	200	7,0	46,596	6	1677,46	59,36	5408,940	432,715	9,546	3846,244	384,624	8,050
250	x	200	8,0	52,785	6	1900,26	67,24	6057,498	484,600	9,491	4303,960	430,396	8,000
250	x	200	10,0	64,815	6	2333,34	82,57	7265,841	581,267	9,381	5154,395	515,440	7,901
250	x	200	12,0	75,407	2	904,88	96,06	8158,656	652,692	9,216	5791,981	579,198	7,765
250	x	200	12,5	78,142	2	937,70	99,54	8396,992	671,759	9,184	5959,676	595,968	7,738
260	x	100	3,0	16,491	6	593,68	21,01	1771,305	136,254	9,182	402,935	80,587	4,379
260	x	100	3,5	19,150	6	689,40	24,39	2043,330	157,179	9,152	463,137	92,627	4,357
260	x	100	4,0	21,782	6	784,15	27,75	2308,869	177,605	9,122	521,434	104,287	4,335
260	x	100	4,5	24,389	6	878,00	31,07	2567,973	197,536	9,091	577,857	115,571	4,313
260	x	100	5,0	26,970	6	970,92	34,36	2820,695	216,977	9,061	632,435	126,487	4,290
260	x	100	6,0	32,054	6	1153,94	40,83	3307,199	254,400	9,000	736,178	147,236	4,246
260	x	100	6,3	33,292	6	1198,51	42,41	3390,357	260,797	8,941	757,332	151,466	4,226
260	x	100	7,0	36,705	6	1321,38	46,76	3697,258	284,404	8,892	822,300	164,460	4,194
260	x	100	8,0	41,481	6	1493,32	52,84	4112,398	316,338	8,822	909,005	181,801	4,148
260	x	100	10,0	50,685	6	1824,66	64,57	4861,979	373,998	8,678	1061,743	212,349	4,055
260	x	100	12,0	58,451	6	2104,24	74,46	5290,512	406,962	8,429	1156,094	231,219	3,940
260	x	100	12,5	60,479	6	2177,24	77,04	5417,051	416,696	8,385	1181,215	236,243	3,916
260	x	140	4,0	24,294	12	1749,17	30,95	2833,199	217,938	9,568	1095,648	156,521	5,950
260	x	140	4,5	27,215	12	1959,48	34,67	3155,556	242,735	9,540	1218,147	174,021	5,928
260	x	140	5,0	30,110	12	2167,92	38,36	3471,028	267,002	9,513	1337,559	191,080	5,905
260	x	140	6,0	35,822	12	2579,18	45,63	4081,535	313,964	9,457	1567,274	223,896	5,860
260	x	140	6,3	37,248	12	2681,86	47,45	4201,506	323,193	9,410	1617,022	231,003	5,838
260	x	140	7,0	41,101	9	2219,45	52,36	4593,613	353,355	9,367	1764,304	252,043	5,805

Perfis Ocos Rectangulares

EN 10219 - 3

Dimensões			Espessura (mm)	Massa Linear (Kg/m)	Tubos por Atado	Peso por Atado (Kg)	Secção (cm ²)	Ixx (cm ⁴)	Wxx (cm ³)	ixx (cm)	Iyy (cm ⁴)	Wyy (cm ³)	Iyy (cm)
260	x	140	8,0	46,505	9	2511,27	59,24	5128,803	394,523	9,304	1964,149	280,593	5,758
260	x	140	10,0	56,965	6	2050,74	72,57	6112,646	470,204	9,178	2327,673	332,525	5,664
260	x	140	12,0	65,987	6	2375,53	84,06	6767,760	520,597	8,973	2581,433	368,776	5,542
260	x	140	12,5	68,329	6	2459,84	87,04	6949,760	534,597	8,935	2648,358	378,337	5,516
260	x	180	4,0	26,806	9	1447,52	34,15	3357,530	258,272	9,916	1917,445	213,049	7,493
260	x	180	4,5	30,041	9	1622,21	38,27	3743,139	287,934	9,890	2135,785	237,309	7,471
260	x	180	5,0	33,250	9	1795,50	42,36	4121,362	317,028	9,864	2349,533	261,059	7,448
260	x	180	6,0	39,590	9	2137,86	50,43	4855,871	373,529	9,812	2763,434	307,048	7,402
260	x	180	6,3	41,204	9	2225,02	52,49	5012,656	385,589	9,772	2856,309	317,368	7,377
260	x	180	7,0	45,497	9	2456,84	57,96	5489,967	422,305	9,733	3125,168	347,241	7,343
260	x	180	8,0	51,529	9	2782,57	65,64	6145,208	472,708	9,676	3493,232	388,137	7,295
260	x	180	10,0	63,245	6	2276,82	80,57	7363,313	566,409	9,560	4174,133	463,793	7,198
260	x	180	12,0	73,523	6	2646,83	93,66	8245,008	634,231	9,383	4679,248	519,916	7,068
260	x	180	12,5	76,179	6	2742,44	97,04	8482,468	652,498	9,349	4811,851	534,650	7,042
300	x	50	3,0	16,020	12	1153,44	20,41	1880,444	125,363	9,599	102,417	40,967	2,240
300	x	50	3,5	18,600	12	1339,20	23,69	2166,215	144,414	9,562	116,505	46,602	2,217
300	x	50	4,0	21,154	12	1523,09	26,95	2444,244	162,950	9,524	129,803	51,921	2,195
300	x	50	4,5	23,682	12	1705,10	30,17	2714,587	180,972	9,486	142,334	56,933	2,172
300	x	50	5,0	26,185	12	1885,32	33,36	2977,300	198,487	9,448	154,121	61,648	2,150
300	x	50	6,0	31,112	12	2240,06	39,63	3480,068	232,005	9,371	175,554	70,222	2,105
300	x	50	6,3	32,302	12	2325,74	41,15	3547,998	236,533	9,286	179,330	71,732	2,088
300	x	50	7,0	35,606	12	2563,63	45,36	3857,819	257,188	9,222	191,682	76,673	2,056
300	x	50	8,0	40,225	12	2896,20	51,24	4272,154	284,810	9,131	207,119	82,848	2,010
300	x	50	10,0	49,115	10	2946,90	62,57	5002,699	333,513	8,942	230,870	92,348	1,921
300	x	100	4,0	24,294	14	2040,70	30,95	3320,457	221,364	10,358	595,205	119,041	4,385
300	x	100	4,5	27,215	14	2286,06	34,67	3697,015	246,468	10,327	660,000	132,000	4,363
300	x	100	5,0	30,110	14	2529,24	38,36	4065,217	271,014	10,295	722,769	144,554	4,341
300	x	100	6,0	35,822	12	2579,18	45,63	4776,788	318,453	10,231	842,354	168,471	4,296
300	x	100	6,3	37,248	12	2681,86	47,45	4906,796	327,120	10,169	868,122	173,624	4,277
300	x	100	7,0	41,101	8	1972,85	52,36	5360,462	357,364	10,118	943,615	188,723	4,245
300	x	100	8,0	46,505	8	2232,24	59,24	5977,860	398,524	10,045	1044,771	208,954	4,199
300	x	100	10,0	56,965	8	2734,32	72,57	7106,032	473,735	9,896	1224,410	244,882	4,108
300	x	100	12,0	65,987	6	2375,53	84,06	7808,314	520,554	9,638	1343,102	268,620	3,997
300	x	100	12,5	68,329	6	2459,84	87,04	8009,593	533,973	9,593	1373,923	274,785	3,973
300	x	150	4,0	27,434	10	1646,04	34,95	4196,670	279,778	10,958	1447,457	192,994	6,436
300	x	150	4,5	30,747	10	1844,82	39,17	4679,444	311,963	10,930	1611,023	214,803	6,413
300	x	150	5,0	34,035	10	2042,10	43,36	5153,134	343,542	10,902	1770,869	236,116	6,391
300	x	150	6,0	40,532	10	2431,92	51,63	6073,508	404,901	10,846	2079,565	277,275	6,346
300	x	150	6,3	42,193	10	2531,58	53,75	6265,595	417,706	10,797	2150,035	286,671	6,325

Perfis Ocos Rectangulares

EN 10219 - 3

Dimensões		Espessura (mm)	Massa Linear (Kg/m)	Tubos por Atado	Peso por Atado (Kg)	Secção (cm ²)	Ixx (cm ⁴)	Wxx (cm ³)	ixx (cm)	Iyy (cm ⁴)	Wyy (cm ³)	Iyy (cm)	
300	x	150	7,0	46,596	10	2795,76	59,36	6863,106	457,540	10,753	2350,016	313,336	6,292
300	x	150	8,0	52,785	8	2533,68	67,24	7683,567	512,238	10,690	2622,953	349,727	6,246
300	x	150	10,0	64,815	6	2333,34	82,57	9209,366	613,958	10,561	3125,029	416,671	6,152
300	x	150	12,0	75,407	6	2714,65	96,06	10298,074	686,538	10,354	3498,050	466,407	6,035
300	x	150	12,5	78,142	6	2813,11	99,54	10594,228	706,282	10,316	3594,782	479,304	6,009
300	x	200	4,0	30,574	6	1100,66	38,95	5072,884	338,192	11,413	2736,559	273,656	8,382
300	x	200	5,0	37,960	6	1366,56	48,36	6241,050	416,070	11,361	3360,921	336,092	8,337
300	x	200	6,0	45,242	6	1628,71	57,63	7370,228	491,349	11,309	3962,188	396,219	8,291
300	x	200	6,3	47,139	6	1697,00	60,05	7624,393	508,293	11,268	4103,817	410,382	8,267
300	x	200	7,0	52,091	6	1875,28	66,36	8365,749	557,717	11,228	4498,387	449,839	8,233
300	x	200	8,0	59,065	6	2126,34	75,24	9389,274	625,952	11,171	5041,667	504,167	8,186
300	x	200	10,0	72,665	6	2615,94	92,57	11312,699	754,180	11,055	6057,729	605,773	8,090
300	x	200	12,0	84,827	4	2035,85	108,06	12787,834	852,522	10,878	6853,741	685,374	7,964
300	x	200	12,5	87,954	4	2110,90	112,04	13178,864	878,591	10,845	7059,936	705,994	7,938
300	x	220	5,0	39,530	6	1423,08	50,36	6676,217	445,081	11,514	4162,689	378,426	9,092
300	x	220	6,0	47,126	6	1696,54	60,03	7888,916	525,928	11,463	4912,752	446,614	9,046
300	x	220	6,3	49,117	6	1768,21	62,57	8167,913	544,528	11,425	5091,093	462,827	9,020
300	x	220	7,0	54,289	6	1954,40	69,16	8966,806	597,787	11,387	5585,087	507,735	8,987
300	x	220	8,0	61,577	6	2216,77	78,44	10071,556	671,437	11,331	6266,901	569,718	8,938
300	x	220	10,0	75,805	6	2728,98	96,57	12154,032	810,269	11,219	7547,790	686,163	8,841
300	x	220	12,0	88,595	4	2126,28	112,86	13783,738	918,916	11,051	8565,826	778,711	8,712
300	x	220	12,5	91,879	4	2205,10	117,04	14212,718	947,515	11,020	8829,401	802,673	8,685

CLASSES DO AÇO

Classe Aço	Características Químicas														
	% por massa														
	C % máx.	Si % máx.	Mn % máx.	P % máx.	S % máx.	Cr % máx.	Mo % máx.	Ni % máx.	Al % total mín.	Cu % máx.	Nb % máx.	Ti % máx.	V % máx.	N % máx.	CEV ≤ 16mm máx.
S420NH	0,22	0,60	1,00 - 1,70	0,030	0,025	0,30	0,10	0,80	0,020	0,55	0,050	0,050	0,20	0,025	0,50
S420NLH				0,025	0,020										
S500MH	0,16	0,60	1,70	0,030	0,020	0,30	0,20	0,80	0,020	0,55	0,090	0,060	0,12	0,025	0,47
S500MLH				0,025	0,015										
S550MH	0,16	0,60	1,80	0,020	0,015	0,30	0,50	0,80	0,015	0,55	0,090	0,150	0,20	0,025	0,47
S550MLH				0,020	0,012										
S600MH	0,16	0,60	1,90	0,020	0,015	0,30	0,50	0,80	0,015	0,55	0,090	0,220	0,20	0,025	0,47
S600MLH				0,020	0,012										
S650MH	0,16	0,60	2,00	0,020	0,015	0,30	0,50	0,80	0,015	0,55	0,090	0,220	0,20	0,025	0,47
S650MLH				0,020	0,012										
S700 MH	0,16	0,60	2,10	0,020	0,015	0,30	0,50	0,80	0,015	0,55	0,090	0,220	0,20	0,025	0,47
S700MLH				0,020	0,012										
S900MH	0,20	0,60	2,20	0,020	0,012	1,60	1,00	0,80	0,015	0,55	0,090	0,250	0,20	0,025	0,60
S960MH	0,20	0,60	2,20	0,020	0,012	1,60	1,00	0,80	0,015	0,55	0,090	0,250	0,20	0,025	0,62

Classe Aço	Características Mecânicas			Energia mínima de resistência ao choque KV2	
	R _{eh} (MPa) mín. (mm)	R _m (MPa) (mm)	A (%) (mm)	- 50 °C	- 20 °C
S420NH	420	520-680	19		
S420NLH					
S500MH	500	580-760	11	27	27
S500MLH					
S550MH	550	600-760	10	27	27
S550MLH					
S600MH	600	650-820	9	27	27
S600MLH					
S650MH	650	700-880	8	27	27
S650MLH					
S700 MH	700	750-950	7	27	27
S700MLH					
S900MH	900	930-1200	5		
S960MH	960	980-1250	4		

CONDIÇÕES DE FORNECIMENTO

ACONDICIONAMENTO

O material é disponibilizado em atados geométricos, cintados com bandas de aço, em formato hexagonal, quadrado e/ou retangular. Para facilitar o manuseamento (carga/descarga) todos os atados são fornecidos com cintas de poliéster adequadas ao peso do atado.

ETIQUETAGEM

Cada atado é fornecido com uma etiqueta fixada por um grampo metálico, garantindo a identificação do produto e consequentemente a rastreabilidade do mesmo.

OPÇÕES DE FORNECIMENTO

GALVANIZAÇÃO POR IMERSÃO

Possibilidade de fornecimento de tubos galvanizados por imersão a quente, de acordo com a norma EN 10240 A.1/ A.2 ou com a ISO 1461, conferindo maior proteção contra a corrosão.

TOLERÂNCIAS ESPECIAIS

As tolerâncias especiais devem ser solicitadas no ato de consulta/encomenda.

SOLDADURA

Possibilidade de remoção do cordão interno de soldadura.
Possibilidade de definição da posição de cordão de soldadura, de acordo com valor objetivo e/ou face do tubo.

APTIDÃO À GALVANIZAÇÃO

Possibilidade de fornecimento de tubos com características químicas que garantam a aptidão à galvanização por imersão a quente.

VALOR EQUIVALENTE DE CARBONO (CEV)

Possibilidade de especificar o valor do CEV no ato de consulta/encomenda.

PROTEÇÃO DA SUPERFÍCIE

Durante o fabrico todos os tubos são revestidos por óleo protetivo, de alto poder hidrofugante, de forma a proteger a superfície contra a corrosão. Salvo indicação contrária pelo cliente no ato da encomenda/consulta.

CERTIFICADO

Na expedição, todas as encomendas são acompanhadas do respetivo certificado de inspeção, segundo a EN 10204, de acordo com a norma de produto aplicável.

SOLDABILIDADE NOS CANTOS

Possibilidade de fornecimento de tubos que cumpram os requisitos compatíveis com a soldabilidade nos cantos, de acordo com EC3.

COMPRIMENTO

Capacidade de fornecimento de tubos com comprimentos específicos, solicitados no ato da consulta/encomenda.

OPERAÇÕES DE DEFORMAÇÃO ESPECÍFICAS (OU ESPECIAIS)

Possibilidade de fornecimento de tubos, de acordo com as mais exigentes capacidades de deformação.

EMBALAMENTO

Os atados poderão ser configurados, de acordo com indicações do cliente, no ato da consulta/ encomenda. Possibilidade de serem utilizadas embalagens com proteção anticorrosiva – VCI.

ENSAIOS LABORATORIAIS

Possibilidade de serem solicitados ensaios laboratoriais específicos, não previstos na norma aplicável (anisotropia, nevoeiro salino, metalografia, alongamento à espessura, entre outros).

ÁREAS DE APLICAÇÃO



INDÚSTRIA



CONSTRUÇÃO



ENERGIA



ENGENHARIA
E ARQUITETURA